



VT7600F Series
RTU Terminal Equipment Controller with
Modulating Heat

Installation Guide

For Commercial HVAC Applications

January 30th, 2012 / 028-377-R2

CONTENTS

| | |
|--|-----------|
| Installation | 2 |
| Location | 2 |
| Installation | 2 |
| Theory of Operation | 3 |
| Features overview | 4 |
| Model Chart | 5 |
| Network ready | 5 |
| Terminal, Identification and Function | 6 |
| Screw terminal arrangement and wiring | 6 |
| Typical Applications | 7 |
| Main outputs wiring | 7 |
| Remote sensor accessories | 8 |
| Configuring and Status Display Instructions | 9 |
| Status display | 9 |
| User interface | 11 |
| User configuring instructions menu | 11 |
| Local keypad interface | 11 |
| Discharge Air Control | 27 |
| Specifications | 28 |
| Drawing & Dimensions | 29 |



INSTALLATION

Remove the security screw on the bottom of Terminal Equipment Controller cover.

- Open unit by pulling on the bottom side of Terminal Equipment Controller (fig. 1).
- Remove wiring terminals from sticker.
- Please read the FCC ID and IC label installed in the cover upon removal of cover for the wireless products.

Location

1. Should not be installed on an outside wall.
2. Must be installed away from any direct heat source.
3. Should not be installed near an air discharge grill.
4. Should not be affected by direct sun radiation.
5. Nothing should restrict vertical air circulation to the Terminal Equipment Controller.

Installation

1. Swing open the Terminal Equipment Controller PCB to the left by pressing the PCB locking tabs (fig. 2).
2. Pull out cables 6" out from the wall.
3. Wall surface must be flat and clean.
4. Insert cable in the central hole of the base.
5. Align the base and mark the location of the two mounting holes on the wall. Install base in the proper orientation. Arrow on base should be facing up.
6. Install anchors in the wall.
7. Insert screws in mounting holes on each side of the base (fig. 2).
8. Gently swing back the circuit board on the base and push on it until the tabs lock it.
9. Strip each wire 1/4 inch from end.

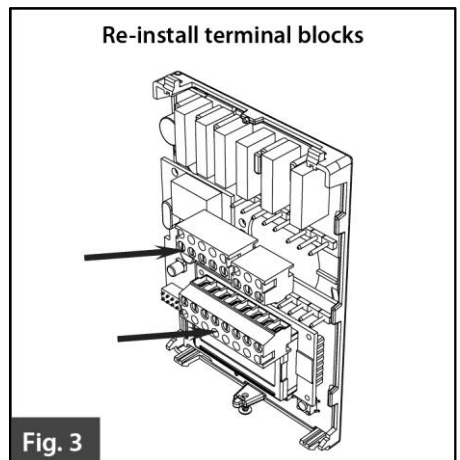
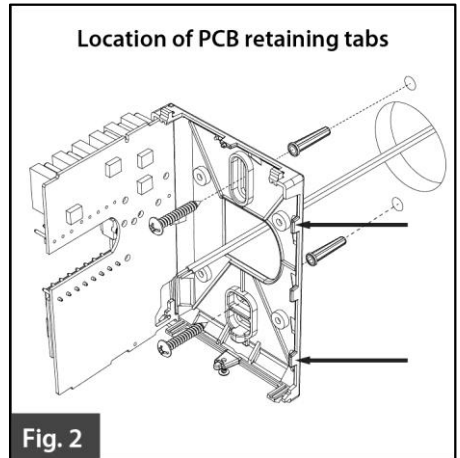
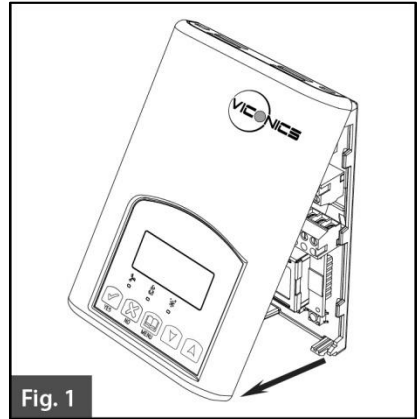

10. Insert each wire according to wiring diagram.
11. Gently push excess wiring back into hole (fig. 3).
12. Re-Install wiring terminals in their correct locations (fig. 3).
13. Re-install the cover (top side first) and gently push extra wire length back into the hole in the wall.
14. Install security screw.



- When replacing an existing Terminal Equipment Controller, label the wires before removal of the Terminal Equipment Controller.
- Electronic controls are static sensitive devices. Discharge yourself properly before manipulating and installing the Terminal Equipment Controller.
- A short circuit or improper wiring may permanently damage the Terminal Equipment Controller or the equipment.
- All VT7000 series Terminal Equipment Controllers are designed for use as operating controls only and are not safety devices. These instruments have undergone rigorous tests and verification prior to shipping to ensure proper and reliable operation in the field. Whenever a control failure could lead to personal injury and or loss of property, it becomes the responsibility of the user or installer or electrical system designer to incorporate safety devices (such as relays, flow switch, thermal protections, etc...) and or an alarm system to protect the entire system against such catastrophic failures. Tampering with the devices or unintended application of the devices will result in a void of warranty.

THEORY OF OPERATION

The VT76X6F series uses a Viconics proprietary adaptive logic algorithm to control the space temperature. This algorithm controls the heating and or air conditioning system to minimize overshoot while still providing comfort. It provides exceptional accuracy due to its unique PI time proportioning control algorithm, which virtually eliminates temperature offset associated with traditional, differential-based on/off thermostats.

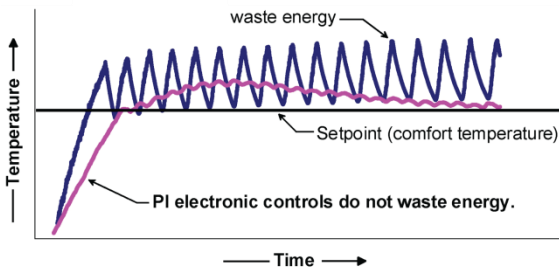

Fig.2 - On/Off mechanical control vs. PI electronic control.

Features overview

- 7 day schedule models, 2 or 4 events.
- Remote outdoor sensing capability for added flexibility.
 - System mode heating and cooling lockout.
 -
- Remote discharge air sensor input for monitoring and control purpose.
 - System efficiency feedback.
 - Discharge high limit heating lockout.
 - Discharge low limit cooling lockout.
 - Minimum supply air temperature.
- Remote return air sensor input that replaces internal on board sensor.
- Password protected configuration menu and lockable keypads for security.
- Two configurable digital input for added flexibility. The input can be configured as the following:
 - **None:** No function will be associated with the input.
 - **Service:** a backlit flashing **Service** alarm will be displayed on the Terminal Equipment Controller LCD screen when the input is energized. It can be tied in to the AC unit control card, which provides an alarm in case of malfunction.
 - **Filter:** a backlit flashing **Filter** alarm will be displayed on the Terminal Equipment Controller LCD screen when the input is energized. It can be tied to a differential pressure switch that monitors filters.
 - **RemNSB:** remote NSB timer clock input. Will disable the internal scheduling of the Terminal Equipment Controller. The scheduling will now be set as per the digital input. The menu part related to scheduling is disabled and no longer accessible. It provides low cost setback operation via occupancy sensor or from a dry contact.
 - **RemOVR:** temporary occupancy contact. Disables all override menu function of the Terminal Equipment Controller. . The override function is now controlled by a manual remote momentarily closed contact. When configured in this mode, the input operates in a toggle mode.
 - With this function enabled it is now possible to toggle between unoccupied & occupied setpoints for the amount of time set by parameter (TOccTime) temporary occupancy time.
- Automatic smart fan operation saves energy during unoccupied periods.
- Non volatile EEPROM memory prevents loss of parameters during power shortage.
- Configurable SPST output relay on scheduling models for lighting, exhaust fan or fresh air control.
- 6 hour typical reserve time for clock in case of power loss.

Easy configuration and self-binding operation

- Easy configuration without using any special software or additional tools.
- Can be used as stand-alone or with BACnet™ MS-TP supervision controller for monitoring purposed.
- Truly scalable in terms of supported number of zones and RTU units.

MODEL CHART

Product Selector

Please refer to the following matrix when ordering:

VT76 5 2 F5500W

| Step 1 | Step 2 | Step 3 | Step 4 | Step 5 | Step 6 |
|--------------|------------------------|------------------------|---|---|--------------------------------|
| MODEL | PROGRAMMABILITY | PROGRAMMABILITY | APPLICATION | PIR OPTIONS | COMMUNICATION OPTIONS |
| | 0 No local scheduling | 0 No local scheduling | F Cooling with 0-10VDC Analog heat output | 50 PIR ready but PIR cover not included | B BACnet [®] MS/TP |
| | 5 Local scheduling | 2 Local Scheduling | | 55 Factory assembled with PIR cover | W Zigbee [®] wireless |
| | | | | | NONE Network Ready |

EXAMPLE:

VT765 2 F 5500W

- Local Scheduling
- Local Scheduling
- Cooling with analog heat output
- Factory installed PIR cover
- Wireless communication

Please note, not all combinations and variants are available. Refer to the Viconics price list for a complete selection listing of all available models.

Network ready

- All Viconics VT7600 series Terminal Equipment Controllers are designed for stand-alone (Network Ready) operation.
- They can be fully integrated into your choice of automation systems using the available communication adapter options.
- If required, stand-alone (Network Ready) Terminal Equipment Controllers can be field retrofitted with the following communication adapters:
 - VCM7600N5000B, Terminal Equipment Controller BACnet[™] MS-TP[®] communication adapter
 - VCM7600N5000W Terminal Equipment Controller wireless Zigbee[™] communication adapter

TERMINAL, IDENTIFICATION AND FUNCTION

| Terminal Use | Terminal Identification | Description |
|--------------------------------|-------------------------|---|
| 1 – Y2 2 nd cooling | Y2 | Second cooling stage output. |
| 2 – Y1 1 st cool | Y1 | First cooling stage output. |
| 3 – G Fan | G | Fan output. |
| 4 – RC 24VAC hot | RC | Power supply of thermostat, hot side. |
| 5 – C 24VAC com | C | Power supply of thermostat, common side. |
| 9 – AO analog heat | AO | Analog 0 – 10 VDC heating output. |
| 10 – Auxiliary output | AUX | Auxiliary output used to disable economizer minimum position or control lighting during unoccupied periods. |
| 11 – DI 1 | DI 1 | Configurable extra digital input. See parameter section for more information. |
| 12 – DI 2 | DI 2 | Configurable extra digital input. See parameter section for more information. |
| 13 – RS | RS | Remote temperature sensor input. |
| 14 - Scom | Scom | Reference input for DI 1, RS, OS & DS. |
| 15 - OS | OS | Outside air temperature sensor input. |
| 16 - DS | MS | Discharge air temperature sensor input. |

Screw terminal arrangement and wiring

VT76XXF Controller Terminals

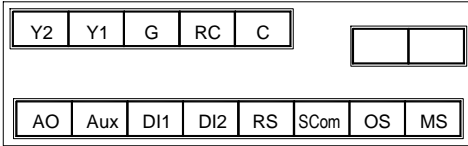

TYPICAL APPLICATIONS

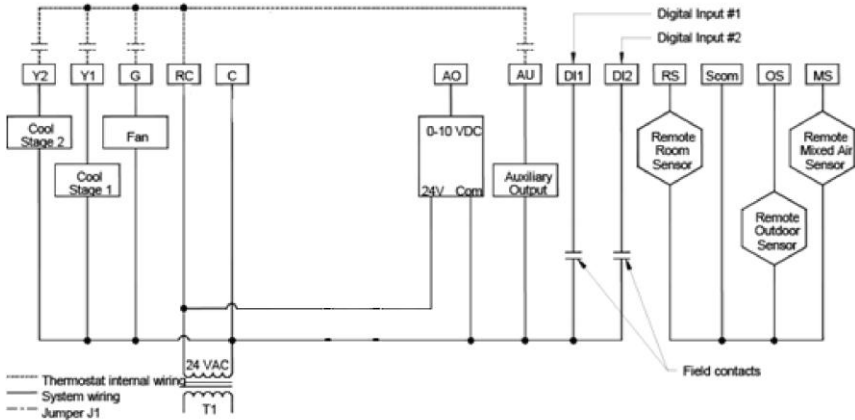

Main outputs wiring

Wiring notes:

- Note 1: If the same power source is used for the heating stages, install jumper across RC & RH. Maximum current is 2.0 amps.
- Note 2: If auxiliary output is used to toggle occupancy of the electronic control card inside the equipment, configure the relay parameter (Aux cont) to the N.O. setting. A second relay can be added for additional functionality of the occupancy output.
- Note 3: The analog outputs and inputs use a half bridge rectifier. Reference of the control signal is the common of the power supply of the Terminal Equipment Controller. (Terminal C)
- Note 4: Electromechanical contacts are to be used with the digital inputs. Electronic triacs cannot be used as mean of switching for the input. The switched leg to the input for the input to activate is terminal C (common)
- Note 5: The transformer of the unit provides power to the t Terminal Equipment Controller and the additional loads that will be wired to the Terminal Equipment Controller.

Remote sensor accessories

| Model no. | Description |
|------------|---------------------------------|
| S2020E1000 | Outdoor temperature sensor |
| S2060A1000 | Averaging temperature sensor |
| S2000D1000 | Duct mounted temperature sensor |

Remote mount temperature sensors use 10K NTC thermistor.

Temperature vs. Resistance Chart for 10 Kohm NTC Thermistor

$$(R_{25^{\circ}\text{C}} = 10\text{K}\Omega \pm 3\% - B_{25/85^{\circ}\text{C}} = 3975\text{K} \pm 1.5\%)$$

| °C | °F | Kohm | °C | °F | Kohm | °C | °F | Kohm | °C | °F | Kohm | °C | °F | Kohm |
|-----|-----|----------|-----|----|---------|----|----|---------|----|-----|---------|----|-----|--------|
| -40 | -40 | 324.3197 | -20 | -4 | 94.5149 | 0 | 32 | 32.1910 | 20 | 68 | 12.4601 | 40 | 104 | 5.3467 |
| -39 | -38 | 303.6427 | -19 | -2 | 89.2521 | 1 | 34 | 30.6120 | 21 | 70 | 11.9177 | 41 | 106 | 5.1373 |
| -38 | -36 | 284.4189 | -18 | 0 | 84.3147 | 2 | 36 | 29.1197 | 22 | 72 | 11.4018 | 42 | 108 | 4.9373 |
| -37 | -35 | 266.5373 | -17 | 1 | 79.6808 | 3 | 37 | 27.7088 | 23 | 73 | 10.9112 | 43 | 109 | 4.7460 |
| -36 | -33 | 249.8958 | -16 | 3 | 75.3299 | 4 | 39 | 26.3744 | 24 | 75 | 10.4443 | 44 | 111 | 4.5631 |
| -35 | -31 | 234.4009 | -15 | 5 | 71.2430 | 5 | 41 | 25.1119 | 25 | 77 | 10.0000 | 45 | 113 | 4.3881 |
| -34 | -29 | 219.9666 | -14 | 7 | 67.4028 | 6 | 43 | 23.9172 | 26 | 79 | 9.5754 | 46 | 115 | 4.2208 |
| -33 | -27 | 206.5140 | -13 | 9 | 63.7928 | 7 | 45 | 22.7861 | 27 | 81 | 9.1711 | 47 | 117 | 4.0607 |
| -32 | -26 | 193.9703 | -12 | 10 | 60.3980 | 8 | 46 | 21.7151 | 28 | 82 | 8.7860 | 48 | 118 | 3.9074 |
| -31 | -24 | 182.2686 | -11 | 12 | 57.2044 | 9 | 48 | 20.7004 | 29 | 84 | 8.4190 | 49 | 120 | 3.7607 |
| -30 | -22 | 171.3474 | -10 | 14 | 54.1988 | 10 | 50 | 19.7390 | 30 | 86 | 8.0694 | 50 | 122 | 3.6202 |
| -29 | -20 | 161.1499 | -9 | 16 | 51.3692 | 11 | 52 | 18.8277 | 31 | 88 | 7.7360 | 51 | 124 | 3.4857 |
| -28 | -18 | 151.6239 | -8 | 18 | 48.7042 | 12 | 54 | 17.9636 | 32 | 90 | 7.4182 | 52 | 126 | 3.3568 |
| -27 | -17 | 142.7211 | -7 | 19 | 46.1933 | 13 | 55 | 17.1440 | 33 | 91 | 7.1150 | 53 | 127 | 3.2333 |
| -26 | -15 | 134.3971 | -6 | 21 | 43.8268 | 14 | 57 | 16.3665 | 34 | 93 | 6.8259 | 54 | 129 | 3.1150 |
| -25 | -13 | 126.6109 | -5 | 23 | 41.5956 | 15 | 59 | 15.6286 | 35 | 95 | 6.5499 | 55 | 131 | 3.0016 |
| -24 | -11 | 119.3244 | -4 | 25 | 39.4921 | 16 | 61 | 14.9280 | 36 | 97 | 6.2866 | 56 | 133 | 2.8928 |
| -23 | -9 | 112.5028 | -3 | 27 | 37.5056 | 17 | 63 | 14.2629 | 37 | 99 | 6.0351 | 57 | 135 | 2.7886 |
| -22 | -8 | 106.1135 | -2 | 28 | 35.6316 | 18 | 64 | 13.6310 | 38 | 100 | 5.7950 | 58 | 136 | 2.6886 |
| -21 | -6 | 100.1268 | -1 | 30 | 33.8622 | 19 | 66 | 13.0307 | 39 | 102 | 5.5657 | 59 | 138 | 2.5926 |

S2000D1000; remote duct mounted temperature sensor c/w junction box.

This sensor can be used for:

- Remote return air temperature sensing with the sensor mounted on the return air duct.
- Outside air temperature sensing with the sensor installed in the fresh air plenum.
- Supply air temperature sensing.



Fig.10 – Remote Duct Mounted Temperature Sensor

S2060A1000; remote averaging duct mounted temperature sensor c/w junction box.

This sensor can be used for:

- Remote averaging return air temperature sensing with the sensor mounted on the return air duct.
- Outside air temperature averaging sensing with the sensor installed in the fresh air plenum.

- Supply air temperature averaging sensor for economizer models with the sensor in the mixing plenum.

S2020E1000; outdoor air temperature sensor

This sensor can be used for:

- Outside air temperature sensing with the sensor installed directly exposed to the elements.
- Sensor uses a water resistant NEMA 4 ABS enclosure for outdoor applications.

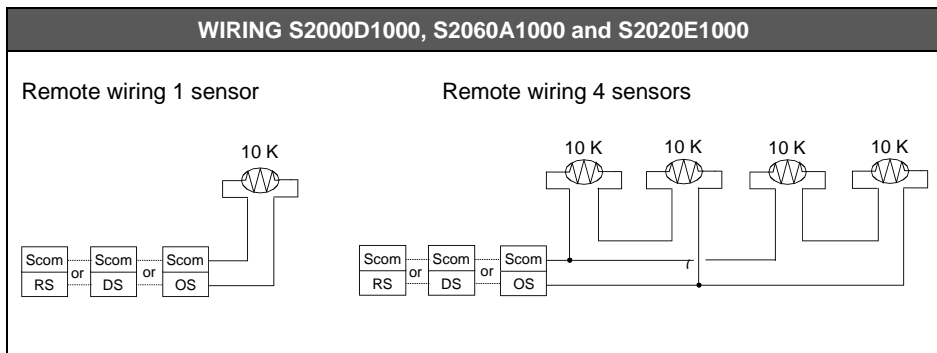

CONFIGURING AND STATUS DISPLAY INSTRUCTIONS

Status display

The Terminal Equipment Controller features a two-line, eight-character display. There is a low level backlight that is always active and can only be seen at night.

When left unattended, the Terminal Equipment Controller has an auto scrolling display that shows the current status of the system.

Each item is scrolled sequentially with the back lighting in low level mode. Pressing any key will cause the back light to come on to high level.

Manual scrolling of each menu item is achieved by pressing the Yes (scroll) key repetitively. The last item viewed will be shown on the display for 30 seconds before returning to automatic scrolling. Temperature is automatically updated when scrolling is held.

Sequence of auto-scroll status display:

| CLOCK STATUS | SYSTEM MODE | SCHEDULE STATUS | OUTDOOR TEMPERATURE | ALARMS |
|-----------------------|------------------|------------------|------------------------|----------|
| Monday 12:00 AM | Sys mode auto | Occupied | Outdoor x.x °C or°F | Service |
| | Sys mode off | Occupied hold | | Frost ON |
| | Sys mode heat | Unoccup | | SetClock |
| | Sys mode cool | | | Filter |
| | | | | Fan lock |
| | | | | DAS Alm |

Outdoor air temperature

- Outdoor air temperature display is only enabled when outdoor air temperature sensor is connected.
- A maximum range status display of 50 °C (122 °F) indicates a shorted sensor. Associated functions, such as mode lockouts and economizer function are automatically disabled.
- A minimum range status -40 °C (-40 °F) is not displayed and indicates a opened sensor or a sensor not connected. Associated functions, such as mode lockouts and economizer function are automatically disabled.

Alarms



- If alarms are detected, they will automatically be displayed at the end of the status display scroll.
- During an alarm message display, the back lit screen will light up at the same time as the message and shut off during the rest of the status display.
- Two alarms maximum can appear at any given time.
- The priority for the alarms is as follows:

Sequence of manual-scroll status display:

Manual scroll of each menu item is achieved by pressing the Yes (scroll) key repetitively. The last item viewed will be shown on the display for 30 seconds before returning to automatic scrolling. Temperature is automatically updated when scrolling is held.

| Clock Status | System Mode | Schedule Status | Outdoor Temperature | Alarms (if detected) |
|--------------------|------------------|-----------------|--------------------------|----------------------|
| Monday 12:00 AM | Sys Mode Off | Occupied | Outdoor xx.x °C or °F | Service |
| | Sys Mode Auto | Unoccupied | | DAS Alrm |
| | Sys Mode Cool | Override | | SetClock |
| | Sys Mode Heat | | | Filter |
| | | | | Fan lock |
| | | | | Frost ON |

| | |
|------------------|--|
| Frost ON | Indicates that the heating is energized by the low limit frost protection room temperature setpoint 5.6 °C (42 °F) |
| SetClock | Indicates that the clock needs to be reset. There has been a power failure which has lasted longer than 6 hours |
| Service | Indicates that there is a service alarm as per one of the configurable digital input (DI1 or DI2) |
| Filter | Indicates that the filters are dirty as per one of the configurable digital input (DI1 or DI2) |
| Fan lock | Indicates that the heating and cooling action are locked out due to a defective fan operation |
| DAS Alarm | Indicates that the discharge air temperature is either too low or too high. |

| | |
|--|---|
| When any of the fan is ON , the FAN LED will illuminate |  |
| When heating is ON , the HEAT LED will illuminate |  |
| When cooling is ON , the COOL LED will illuminate |  |

USER INTERFACE

User configuring instructions menu

The VT76X6FX series of controllers feature an intuitive, menu-driven, back-lit LCD display that walks users and installers through the configuring steps, making the configuring process extremely simple. This menu is typically accessed by the user to set the parameters such as the clock time set, the schedule time events and the system mode.

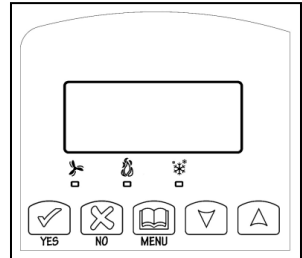





It is possible to bring up the user menu at any time by depressing the MENU key. The status display automatically resumes after exiting the user-configuring menu.

If the user pauses at any given time during configuring, **Auto Help** text is displayed to help and guide the user through the usage and configuring of the controller.

Ex.: Press yes key to change cooling temperature setpoint
Use the up or down arrow to adjust cooling setpoint

Each of the sections in the menu is accessed and configured using 5 keys on the controller cover. The priority for the alarms is as follows:

Local keypad interface

| | |
|--|---|
|  | The YES key is used to confirm a selection, to move onto the next menu item and to manually scroll through the displayed information. |
|  | The NO key is used when you do not desire a parameter change, and to advance to the next menu item. Can also be used to toggle between heating and cooling setpoints. |
|  | The MENU key is used to access the Main User Menu or exit the menu. |
|  | The down arrow key is used to decrease temperature setpoint and to adjust the desired values when configuring the Terminal Equipment Controller. |
|  | The up arrow key is used to increase temperature setpoint and to adjust the desired values when configuring the Terminal Equipment Controller. |

When left unattended for 45 seconds, the display will resume automatic status display scrolling.

To turn on the back light, press any key on the front panel. The back lit display will turn off automatically after 45 seconds.

Sequence of user menu:

| | | | |
|------------------------------------|--------------------------------|------------------------------|--------------------------|
| Override Resume | System mode setting | Schedules setting | Clock setting |
| Override sched Y/N | Sys mode set Y/N | Schedule set Y/N | Clock set Y/N |
| Appears only in unoccupied mode | | | |
| Cancel ovrd Y/N | | | |
| Appears only in override mode | | | |

A) Override an unoccupied period

**Override
sched Y/N**

This menu will appear only when the Terminal Equipment Controller is in unoccupied mode. The unoccupied mode is enabled either by the internal timer scheduling or by a remote NSB contact via DI1 or DI2.

If DI1 or DI2 is configured to operate as a remote temporary override contact, this menu will be disabled.

Answering yes to this prompt will cause the Terminal Equipment Controller to go into occupied mode for an amount of time equal to the parameter "TOccTime" (1 to 12 hours).

B) Resume regular scheduling

**Cancel
ovrd Y/N**

This menu does not appear in regular operation. It will appear only when the Terminal Equipment Controller is in Unoccupied override mode.

Answering "Yes" to this question will cause the Terminal Equipment Controller to resume the regular setpoints & scheduling.

C) Temperature setpoints

Permanent setpoint changes

**Temperat
set Y/N**

This menu permits the adjustment of all permanent temperature setpoints (occupied and unoccupied) as well as the desired temperature units (°F or °C). Permanent setpoints are written to RAM and EEPROM.

| COOLING SETPOINT OCCUPIED MODE | | HEATING SETPOINT OCCUPIED MODE | | COOLING SETPOINT UNOCCUPIED MODE | | HEATING SETPOINT UNOCCUPIED MODE | | °F OR °C DISPLAY SETTING | |
|--|----------------------------|--------------------------------|----------------------------|----------------------------------|----------------------------|----------------------------------|----------------------------|--------------------------|----------------------------|
| Cooling set? Y/N | No next → Yes down ↓ | Heating set? Y/N | No next → Yes down ↓ | Unocc CL set? Y/N | No next → Yes down ↓ | Unocc HT set? Y/N | No next → Yes down ↓ | °F or °C set? Y/N | No next → Yes down ↓ |
| Use ▲▼ keys to set value, Yes key to confirm | | | | | | | | | |
| Cooling 70.0 °F | Use ▲▼ To set value | Heating 68.00 °F | Use ▲▼ To set value | Unocc CL 80.0 °F | Use ▲▼ To set value | Unocc HT 60.0 °F | Use ▲▼ To set value | Units °F | Use ▲▼ To set value |

Temporary setpoint changes

Temporary setpoints can be modified through the Up arrow key (▲) and the Down arrow keys (▼).

User will be prompted with the present mode (Heating or Cooling) of the Terminal Equipment Controller and its setpoint.

The Up (▲) arrow key will increment the setpoint by 0.5 degree (F or C).

The Down (▼) arrow key will decrement the setpoint by 0.5 degree (F or C).

Press the Yes key to accept the new setpoint.

Local changes to the heating or cooling setpoints made by the user directly using the up or down arrow are temporary.

They will remain effective for the duration specified by TocTime.

Setpoints will revert back to their default value after internal timer TocTime expires.

If a permanent change to the setpoints is required, use the **Temperat set ?** menu

D) System mode setting

**Sys mode
set Y/N**

This menu is accessed to set system mode operation

Use ▲▼ to set value, Yes key to confirm

| | |
|---------------------------|---|
| Sys mode auto | Automatic mode Automatic changeover mode between heating and cooling operation |
| Sys mode cooling | Cooling mode Cooling operation mode only |
| Sys mode heating | Heating mode Heating operation mode only |
| Sys mode emergency | Emergency heat mode (heat pump models only) Forced auxiliary heat operation mode only |
| Sys mode off | Off mode Normal cooling or heating operation disabled If enabled in installer parameters, only the automatic heating frost protection at 50 °F (10 °C) is enabled |

E) Fan mode setting

Fan mode set Y/N

This section of the menu is permits the setting of the fan mode operation. Use ▲▼ to set value, Yes key to confirm

| | |
|-----------------------|---|
| Fan mode On | On fan mode Fan is on continuously, even when system mode is OFF. |
| Fan mode Auto | Automatic fan mode Fan cycles on a call for heating or cooling for both occupied & unoccupied periods. |
| Fan mode Smart | Smart fan mode During occupied periods, fan is on continuously. In unoccupied mode, fan cycles on a call for heating or cooling. This selection is available on all models with a communication module, on all stand-alone (Network Ready) scheduling models or if DI1 or DI2 is set to RemNSB on stand-alone non-scheduling models. |

F) Schedule set (2 events)

Scheduling can have 2 or 4 events per day. This is set in the configuration menu as per parameter (2/4event)

Schedule set Y/N

This section of the menu permits the user to set the whether 2 or 4 events is needed. Each day can be tailored to specific schedules if needed.

- 2 events can be scheduled per day.
- Occupied & unoccupied periods can be set for each day.

| MONDAY TIMER SCHEDULE SET | | TUESDAY TIMER SCHEDULE SET | | WEDNESDAY TIMER SCHEDULE SET | | OTHER DAYS ARE IDENTICAL | |
|---|----------------------------|----------------------------|----------------------------|------------------------------|----------------------------|--|--|
| Monday set? Y/N | No next → Yes down ↓ | Tuesday set? Y/N | No next → Yes down ↓ | Wednesda set? Y/N | No next → Yes down ↓ | Selects the day to be scheduled or modified | |
| Yes key to access day scheduling, No key to jump to next day | | | | | | | |
| Occupied Day? Y/N | No next → Yes down ↓ | Occupied Day? Y/N | No next → Yes down ↓ | Occupied Day? Y/N | No next → Yes down ↓ | Yes = Daily schedules will be accessed No = Unoccupied mode all day | |
| Yes key to access day scheduling, No key to jump to next day | | | | | | | |
| | | Copy Y/N Previous | Yes next → No down ↓ | Copy Y/N Previous | Yes next → No down ↓ | Yes = Will copy previous day schedule No = Daily schedules will be accessed | |
| Yes key to copy previous day, No key to set new time value for each day | | | | | | | |
| Occupied 00:00 AM | Use ▲▼ To set value | Occupied 00:00 AM | Use ▲▼ To set value | Occupied 00:00 AM | Use ▲▼ To set value | Sets Event # 1 Occupied time Will activate occupied setpoints | |
| Use ▲▼ to set value, Yes key to confirm | | | | | | | |
| Unoccup 00:00 AM | Use ▲▼ To set value | Unoccup 00:00 AM | Use ▲▼ To set value | Unoccup 00:00 AM | Use ▲▼ To set value | Sets Event # 2 Unoccupied time Will activate unoccupied setpoints | |

Use ▲▼ to set value, Yes key to confirm

Typical examples of a 2 event office schedule:

Ex. #1 Office building closed all weekend

| Event | Period #1 - Event #1 | | Period #1 - Event #2 | | Daily Occupancy |
|-----------|----------------------|---------------|----------------------|---------------|-----------------|
| | Occupied | | Unoccupied | | |
| Setpoint | Cool 72 °F | Heat 70 °F | Cool 80 °F | Heat 62 °F | |
| Monday | 7.00 AM | | 6.00 PM | | Day time only |
| Tuesday | 7.00 AM | | 6.00 PM | | Day time only |
| Wednesday | 7.00 AM | | 6.00 PM | | Day time only |
| Thursday | 7.00 AM | | 6.00 PM | | Day time only |
| Friday | 7.00 AM | | 6.00 PM | | Day time only |
| Saturday | 12.00 PM * | | 12.00 PM * | | Unoccupied |
| Sunday | 12.00 PM * | | 12.00 PM * | | Unoccupied |

* Scheduling consecutive events to the same time will cause the Terminal Equipment Controller to choose the last event as the time at which it will set its schedule. In the above example, the Terminal Equipment Controller will control to the unoccupied set point until 7:00 AM Monday.

Ex. #2 Commercial building which is occupied all weekend

| Event | Period #1 - Event #1 | | Period #1 - Event #2 | | Daily Occupancy |
|-----------|----------------------|---------------|----------------------|---------------|-----------------|
| | Occupied | | Unoccupied | | |
| Setpoint | Cool 72 °F | Heat 70 °F | Cool 80 °F | Heat 62 °F | |
| Monday | 8.00 AM | | 5.00 PM | | Day time only |
| Tuesday | 8.00 AM | | 5.00 PM | | Day time only |
| Wednesday | 8.00 AM | | 5.00 PM | | Day time only |
| Thursday | 8.00 AM | | 5.00 PM | | Day time only |
| Friday | 8.00 AM | | 5.00 PM | | Day time only |
| Saturday | 12.00 AM ** | | 11.59 PM ** | | Occupied |
| Sunday | 12.00 AM ** | | 11.59 PM ** | | Occupied |

** To schedule a day as occupied for 24 hours, set that day occupied time to 12:00 AM and Unoccupied time to 11:59 PM There will be a 1 minute unoccupied period every night at 11:59 PM with this schedule configuration.

Note: 12:00 PM = Noon
12:00 AM = Midnight

G) Schedule set (4 events)

Schedule
set Y/N

This section of the menu permits the user to set the whether 2 or 4 events is needed. Each day can be tailored to specific schedules if needed.

- 4 events can be scheduled per day.
- Occupied & Unoccupied periods can be set for each day.
- Scheduling the 3rd. & 4th. Events to the same time will cancel the last period.

| Monday timer Schedule set | | Tuesday timer Schedule set | | Wednesday timer Schedule set | | Other days are identical |
|---|----------------------------|-------------------------------|---------------------------|---------------------------------|----------------------------|--|
| Monday set? Y/N | No next → Yes down ↓ | Tuesday set? Y/N | No next → Yes down ↓ | Wednesda set? Y/N | No next → Yes down ↓ | Selects the day to be scheduled or modified |
| Yes key to access day scheduling, No key to jump to next day | | | | | | |
| Occupied Day? Y/N | No next → Yes down ↓ | Occupied Day? Y/N | No next → Yes down ↓ | Occupied Day? Y/N | No next → Yes down ↓ | Yes = Daily schedules will be accessed No = Unoccupied mode all day |
| Yes key to access day scheduling, No key to jump to next day | | | | | | |
| | | Copy Y/N Previous | Yes next → No down ↓ | Copy Y/N Previous | Yes next → No down ↓ | Yes = Will copy previous day schedule No = Daily schedules will be accessed |
| Yes key to copy previous day, No key to set new time value for each day | | | | | | |
| Occupied 00:00 AM | Use ▲▼ To set value | Occupied 00:00 AM | Use ▲▼ To set value | Occupied 00:00 AM | Use ▲▼ To set value | Sets Event # 1 Occupied time Will activate occupied setpoints |
| Use ▲▼ to set value, Yes key to confirm | | | | | | |
| Unoccup 00:00 AM | Use ▲▼ To set value | Unoccup 00:00 AM | Use ▲▼ To set value | Unoccup 00:00 AM | Use ▲▼ To set value | Sets Event # 2 Unoccupied time Will activate unoccupied setpoints |
| Use ▲▼ to set value, Yes key to confirm | | | | | | |
| Occupie2 00:00 AM | Use ▲▼ To set value | Occupie2 00:00 AM | Use ▲▼ To set value | Occupie2 00:00 AM | Use ▲▼ To set value | Sets Event # 3 Occupied time Will activate occupied setpoints |
| Use ▲▼ to set value, Yes key to confirm | | | | | | |
| Unoccup2 00:00 AM | Use ▲▼ To set value | Unoccup2 00:00 AM | Use ▲▼ To set value | Unoccup2 00:00 AM | Use ▲▼ To set value | Sets Event # 4 Unoccupied time Will activate unoccupied setpoints |
| Use ▲▼ to set value, Yes key to confirm | | | | | | |

Ex. #1 Four event retail establishment schedule

| Event | Period 1 - Event 1 | | Period 1 - Event 2 | | Period 2 - Event 3 | | Period 2 - Event 4 | | Daily Occupancy |
|------------------|--------------------|--------------|--------------------|--------------|--------------------|---------------|--------------------|---------------|-----------------------|
| | Setpoint | Occupied | Unoccupied | Unoccupied | Occupied | Unoccupied | Occupied | Unoccupied | |
| | Cool 72°F | Heat 70°F | Cool 80°F | Heat 62°F | Cool 72°F | Heat 70 °F | Cool 80°F | Heat 62 °F | |
| Monday | 7.00 AM | | 5.00 PM | | 12.00 PM * | | 12.00 PM * | | Day time only |
| Tuesday | 7.00 AM | | 5.00 PM | | 12.00 PM * | | 12.00 PM * | | Day time only |
| Wednesday | 7.00 AM | | 5.00 PM | | 12.00 PM * | | 12.00 PM * | | Day time only |
| Thursday | 7.00 AM | | 5.00 PM | | 7.00 PM | | 10.30 PM | | Day/evening time only |
| Friday | 7.00 AM | | 5.00 PM | | 7.00 PM | | 10.30 PM | | Day/evening time only |
| Saturday | 12.00 PM * | | 12.00 PM * | | 12.00 PM * | | 12.00 PM * | | Unoccupied |
| Sunday | 12.00 PM * | | 12.00 PM * | | 12.00 PM * | | 12.00 PM * | | Unoccupied |

* Scheduling events to the same time will cancel the last period and leave the Terminal Equipment Controller in unoccupied mode

Ex. #2 Residential

| Event | Period 1 - Event 1 | | Period 1 - Event 2 | | Period 2 - Event 3 | | Period 2 - Event 4 | | Daily Occupancy |
|------------------|--------------------|--------------|--------------------|--------------|--------------------|--------------|--------------------|--------------|-----------------------|
| | Setpoint | Occupied | Unoccupied | Unoccupied | Occupied | Unoccupied | Occupied | Unoccupied | |
| | Cool 72°F | Heat 70°F | Cool 80°F | Heat 62°F | Cool 72°F | Heat 70°F | Cool 80°F | Heat 62°F | |
| Monday | 6:00 AM | | 8:00 AM | | 4:00 PM | | 10:00 PM | | Day/evening time only |
| Tuesday | 6:00 AM | | 8:00 AM | | 4:00 PM | | 10:00 PM | | Day/evening time only |
| Wednesday | 6:00 AM | | 8:00 AM | | 4:00 PM | | 10:00 PM | | Day/evening time only |
| Thursday | 6:00 AM | | 8:00 AM | | 4:00 PM | | 10:00 PM | | Day/evening time only |
| Friday | 6:00 AM | | 8:00 AM | | 4:00 PM | | 11:30 PM | | Day/evening time only |
| Saturday | 8:00 AM * | | 8:00 AM * | | 8:00 AM * | | 11:59 PM * | | Day time only |
| Sunday | 12:00 AM * | | 12:00 AM * | | 12:00 AM * | | 11:59 PM * | | Occupied all day |

* Scheduling consecutive events to the same time will cause the Terminal Equipment Controller to choose the last event as the time at which it will set its schedule. In the above example for Saturday, the Terminal Equipment Controller will control to the occupied set point from 8:00 AM until 11:59 PM. Since it is desired to be in occupied mode throughout the night, then it is necessary to schedule the first event on Sunday at 12:00 AM. The Terminal Equipment Controller will force a one minute unoccupied period for a one minute period (between 11:59 PM and 12:00 AM on Saturday).

H) Clock/Day Settings

Clock
set Y/N

This section of the menu permits the user to set the time and day.

| Time setting | | Day setting | | Time format setting | |
|---------------|-------------------------|--------------|-------------------------|---------------------|-------------------------|
| Time set? Y/N | No next → Yes down ↓ | Day set? Y/N | No next → Yes down ↓ | 12/24hrs set? Y/N | No = exit Yes down ↓ |
| Time 0:00 | Use ▲▼ To set value | Day Monday | Use ▲▼ To set value | 12/24hrs 12 hrs | Use ▲▼ To set value |

J) Schedule hold

Schedule
hold Y/N

- This menu will only appear on stand-alone (Network Ready) Terminal Equipment Controller, i.e. without a BACnet™ / Echelon™ module.
- This section of the menu permits the user to set a permanent schedule hold, which bypasses the internal Terminal Equipment Controller scheduling.
- The permanent schedule hold function is typically used for non-scheduled events that extend for various periods of time.
- Enabling a permanent occupied or permanent unoccupied schedule hold will cancel any active override.
- The use of temporary setpoints during permanent hold is permitted. The duration of the temporary setpoint is as set per the TOccTime parameter.
Ex. 3 hours

Use ▲▼ to set value, yes key to confirm

| CONFIGURATION PARAMETERS DEFAULT VALUE | SIGNIFICANCE AND ADJUSTMENTS |
|--|--|
| <p>PswrdSet Configuration parameters menu access password Default value = 0 No password prompted</p> | <p>This parameter sets a password access to prevent unauthorized access to the configuration menu parameters. A default value of "0" will not prompt a password or lock the access to the configuration menu. Range is: 0 to 1000</p> |
| <p>Com addr Thermostat networking address Default value = 254 Range is: 0 to 254</p> | <p>Conditional parameter to BACnet MS-TP models (VT76xxX5x00B) Conditional parameter to Wireless models (VT76xxX5x00W)</p> <p>This parameter will only appear when a BACnet or wireless network adapter is present. If the thermostat is installed as a stand-alone unit or with an Echelon adapter, this parameter will not be used or displayed</p> <ul style="list-style-type: none"> - For BACnet MS-TP models valid range to use is from 1 to 127. Default value of 254 disables BACnet communication for the thermostat. - For wireless models valid range is 0 to 254 with a maximum of 30 thermostat per VWG |
| <p>PAN ID Personal Area Network Identification Default value = 0 Range is: 0 to 1000</p> | <p>Conditional parameter to Wireless models (VT76xxX5x00W)</p> <p>This parameter will only appear when a wireless network adapter is present. If the Terminal Equipment Controller is installed as a stand-alone (Network Ready) unit or with a BACnet™ or Echelon™ adapter, this parameter will not be used or displayed</p> <p>This parameter (Personal Area Network Identification) is used to link specific Terminal Equipment Controllers to a single specific Viconics wireless gateway (VWG) For every Terminal Equipment Controller reporting to a gateway (maximum of 30 Terminal Equipment Controllers per gateway), be sure you set the SAME PAN ID value both at the gateway and the Terminal Equipment Controller(s).</p> <p>The default value of 0 is NOT a valid PAN ID.</p> |

Channel

Channel selection

Default value = **10**

Range is: **10 to 26**

**Conditional parameter to Wireless models
(VT76xxX5x00W)**

This parameter will only appear when a wireless network adapter is present. If the Terminal Equipment Controller is installed as a stand-alone (Network Ready) unit or with a BACnet™ or Echelon™ adapter, this parameter will not be used or displayed

This parameter (Channel) is used to link specific Terminal Equipment Controllers to specific Viconics wireless gateway(s) (VWG) For every Terminal Equipment Controller reporting to a gateway (maximum of 30 Terminal Equipment Controllers per gateway), be sure you set the SAME channel value both at the gateway and the Terminal Equipment Controller(s).

Viconics recommends using only the usage of channels 15 and 25 only.

The default value of 10 is **NOT** a valid channel. The valid range of available channel is from 11 to 26

| | |
|---|---|
| <p>DI 1</p> <p>Digital input no.1 configuration</p> <p>Open contact input = function not energized</p> <p>Closed contact input = function energized</p> <p>Default value = None</p> | <p>None, No function will be associated with the input</p> <p>Rem NSB, remote NSB timer clock input. Will disable the internal scheduling of the thermostat. The scheduling will now be set as per the digital input. The time is still displayed as information, but the menu part related to scheduling is disabled and no longer accessible.</p> <p>Open contact = occupied setpoints</p> <p>Closed contacts = unoccupied setpoints</p> <p>RemOVR Temporary override remote contact. Disables all override menu function of the thermostat. The override function is now controlled by a manual remote momentarily closed contact. When configured in this mode, the input operates in a toggle mode. With this function enabled it is now possible to toggle between unoccupied & occupied setpoints for the amount of time set by parameter (TOccTime) temporary occupancy time. When Override is enabled, an Override status message will be displayed</p> <p>Filter, a back-lit flashing Filter alarm will be displayed on the thermostat LCD screen when the input is energized</p> <p>Service, a back-lit flashing Service alarm will be displayed on the thermostat LCD screen when the input is energized</p> <p>Fan lock, a back-lit flashing Fan lock alarm will be displayed on the thermostat LCD screen when the input is not energized. Used in conjunction with a local airflow sensor connected to the input. Locks out the thermostat heating and cooling action if no airflow is detected 10 seconds after the fan (G terminal) is energized.</p> <p>Open contact = no airflow</p> <p>Closed contacts = airflow present</p> |
| <p>DI 2</p> <p>Digital input no.2 configuration</p> <p>Open contact input = function not energized</p> <p>Closed contact input = function energized</p> <p>Default value = None</p> | <p>Same as above. It is possible to configure both inputs to have the same function.</p> |
| <p>MenuScro</p> <p>Menu scroll</p> <p>Default value = On = Scroll active</p> | <p>Removes the scrolling display and only present the room temperature/humidity to the user. With this option enabled, no status is given of mode, schedule and outdoor temperature.</p> <p>On = Scroll active</p> <p>Off = Scroll not active</p> |

| | |
|--|--|
| Lockout Keypad lockout levels Default value = 0 No lock | 0 = No lock 1 = Low level 2 = High level |
|--|--|

USER KEY FUNCTIONS

| LEVEL | Resume/ Override scheduling | Permanent Occupied and Unoccupied Setpoints | Temporary setpoints using arrows | System mode setting | Fan mode setting | Schedules setting | Clock setting | Permanent hold |
|---|--------------------------------|--|---|---------------------|------------------|-------------------|---------------|----------------|
| 0 | | | | | | | | |
| 1 | | | | | | | | |
| 2 | | | | | | | | |
| pwr del Power-up delay Default value = 10 seconds | | | On initial power up of the Terminal Equipment Controller (each time 24 VAC power supply is removed & re-applied) there is a delay before any operation is authorized (fan, cooling or heating). This can be used to sequence start up multiple units / Terminal Equipment Controller in one location. 10 to 120 seconds | | | | | |
| Frost pr Frost protection enabled Default value = Off | | | Off: no room frost protection On: room frost protection enabled in all system mode at: 42 °F (5.6 °C) Frost protection is enabled even in system Off mode Off or On On heat pump models the system mode will be forced to EMERGENCY mode if frost protection is activated | | | | | |
| heat max Maximum heating setpoint limit Default value = 90 °F (32 °C) | | | Maximum occupied & unoccupied heating setpoint adjustment. Heating setpoint range is: 40 to 90 °F (4.5 to 32.0 °C) | | | | | |
| cool min Minimum cooling setpoint limit Default value = 54 °F (2 °C) | | | Minimum occupied & unoccupied cooling setpoint adjustment. Cooling setpoint range is: 54 to 100 °F (12.0 to 37.5 °C) | | | | | |

| <p>Pband Proportional Band setting Default value 2 = 2.0 °F (0.6 °C)</p> | <p>Adjust the proportional band used by the Terminal Equipment Controller PI control loop.</p> <p> Note that the default value of 2.0 °F (1.1 °C) gives satisfactory operation in most normal installation cases. The use of a superior proportional band different than the factory one is normally warranted in applications where the Terminal Equipment Controller location is problematic and leads to unwanted cycling of the unit. A typical example is a wall mounted unit where the Terminal Equipment Controller is installed between the return and supply air feeds and is directly influenced by the supply air stream of the unit.</p> <table border="1" data-bbox="497 427 891 683"> <thead> <tr> <th>Value</th> <th>F scale Pband</th> <th>C scale Pband</th> </tr> </thead> <tbody> <tr> <td>2</td> <td>2 F</td> <td>1.1 C</td> </tr> <tr> <td>3</td> <td>3 F</td> <td>1.7 C</td> </tr> <tr> <td>4</td> <td>4 F</td> <td>2.2 C</td> </tr> <tr> <td>5</td> <td>5 F</td> <td>2.8 C</td> </tr> <tr> <td>6</td> <td>6 F</td> <td>3.3 C</td> </tr> <tr> <td>7</td> <td>7 F</td> <td>3.9 C</td> </tr> <tr> <td>8</td> <td>8 F</td> <td>4.4 C</td> </tr> </tbody> </table> | Value | F scale Pband | C scale Pband | 2 | 2 F | 1.1 C | 3 | 3 F | 1.7 C | 4 | 4 F | 2.2 C | 5 | 5 F | 2.8 C | 6 | 6 F | 3.3 C | 7 | 7 F | 3.9 C | 8 | 8 F | 4.4 C |
|--|---|---------------|---------------|---------------|---|-----|-------|---|-----|-------|---|-----|-------|---|-----|-------|---|-----|-------|---|-----|-------|---|-----|-------|
| Value | F scale Pband | C scale Pband | | | | | | | | | | | | | | | | | | | | | | | |
| 2 | 2 F | 1.1 C | | | | | | | | | | | | | | | | | | | | | | | |
| 3 | 3 F | 1.7 C | | | | | | | | | | | | | | | | | | | | | | | |
| 4 | 4 F | 2.2 C | | | | | | | | | | | | | | | | | | | | | | | |
| 5 | 5 F | 2.8 C | | | | | | | | | | | | | | | | | | | | | | | |
| 6 | 6 F | 3.3 C | | | | | | | | | | | | | | | | | | | | | | | |
| 7 | 7 F | 3.9 C | | | | | | | | | | | | | | | | | | | | | | | |
| 8 | 8 F | 4.4 C | | | | | | | | | | | | | | | | | | | | | | | |
| <p>Anticycle Minimum on/off operation time for stages Default value = 2 minutes</p> | <p>Minimum On/Off operation time of cooling & heating stages.</p> <p>IMPORTANT, <i>anti-short cycling can be set to 0 minutes for equipment that posses their own anti cycling timer. Do <u>not</u> use this value unless the equipment is equipped with such internal timer. Failure to do so can damage the equipment.</i> 0, 1, 2, 3, 4 & 5 minutes</p> <p>Anti-short cycling can be set to 0 minutes for equipment that posses their own anti cycling timer. Do not use that value unless the equipment is equipped with such internal timer. Failure to do so can damage the equipment.</p> | | | | | | | | | | | | | | | | | | | | | | | | |
| <p>Min SH Minimum supply heat temperature setpoint Default value = 64 °F (18 °C)</p> | <p>Sets the minimum supply heat to be maintained by the controller during occupied periods (Occupied or Temporary Override).</p> <p>From 50 °F up to 72 °F (10 °C up to 22 °C) (increments: 0.5° or 5°)</p> | | | | | | | | | | | | | | | | | | | | | | | | |

| | |
|--|---|
| <p>cool cph Cooling stages cycles per hour Default value = 4 C.P.H.</p> | <p>Will set the maximum number of cooling stage cycles per hour under normal control operation. It represents the maximum number of cycles that the equipment will turned on and off in one hour. Note that a higher C.P.H will represent a higher accuracy of control at the expense of wearing mechanical components faster. 3 or 4 C.P.H.</p> <p>For multi stage models, cool cph applies to Y1 & Y2</p> <p>For heat pump models, cool cph applies to Y1 & Y2 in cooling and heating independently of the reversing valve position</p> |
| <p>deadband Minimum deadband Default value = 2.0 °F (1.1 °C)</p> | <p>Minimum deadband value between the heating and cooling setpoints. If modified, it will be applied only when any of the setpoints are modified. 2, 3 or 4 °F (1.0 to 2.0 °C)</p> |
| <p>fan cont Fan control Default value = On</p> | <p>Fan control in heating mode. When selecting On; the Terminal Equipment Controller in all cases will always control the fan (terminal G). Valid for On or Auto fan mode When selecting Off; the fan (terminal G), when heating stages (terminals W1 & W2) are solicited, will not be energized. The fan in this case will be controlled by the equipment fan limit control. Valid only for Auto fan mode. On fan mode will leave the fan always on. <i>ON OR OFF</i></p> <p>For multi stage models, fan control applies to W1 & W2</p> <p>For heat pump models, fan control applies to W1 only (Emergency heat)</p> |
| <p>fan del Fan delay Default value = Off</p> | <p>Fan delay extends fan operation by 60 seconds after the call for heating or cooling ends. Valid only for Auto fan mode. "On" fan mode will leave the fan always on. Off or On</p> |
| <p>TocTime Temporary occupancy time Default value = 3 hours</p> | <p>Temporary occupancy time with occupied mode setpoints when override function is enabled When the Terminal Equipment Controller is in unoccupied mode, function is enabled with either the menu or DI1 or DI2 configured as remote override input. 0,1, 2, 3, 4, 5, 6, 7, 8, 9, 10, 11 & 12 hours</p> |
| <p>Cal RS Room air temperature sensor calibration Default value = 0.0 °F or °C</p> | <p>Offset that can be added/subtracted to actual displayed room temperature ± 5.0 °F (± 2.5 °C)</p> |

| | |
|---|---|
| <p>Cal OS Outside air temperature sensor calibration Default value = 0.0 °F or °C</p> | <p>Offset that can be added/subtracted to actual displayed outside air temperature ± 5.0 °F (± 2.5 °C)</p> |
| <p>SH lock Outside air temperature supply heat lockout Default value = 32 °F (0 °C)</p> | <p>Disables heating operation based on outdoor air temperature. Please refer to the Viconics Zoning System Guide for recommended settings. From -15 °F up to 120 °F (-26 °C up to 49 °C) (increments: 5° or 50°)</p> |
| <p>C stage Number of cooling stages Default value = 2 stages</p> | <p>Will revert the operation of 2 stage Terminal Equipment Controller to single stage operation only when the second cooling step is not needed. 1 or 2 stages</p> |
| <p>H lock Outside air temperature heating lockout Default value = 120 °F (49 °C)</p> | <p>Disables heating stage operation based on outdoor air temperature. Function will only be enabled if OS (outside air temperature sensor) is connected. From -15 °F up to 120 °F (-26 °C up to 49 °C)</p> |
| <p>C lock Outside air temperature mechanical cooling lockout. Default value = -40 °F (-40 °C)</p> | <p>Disables cooling stage operation based on outdoor air temperature. On economizer model, free cooling will not be disabled by this function. Function will only be enabled if OS (outside air temperature sensor) is connected. From -40 °F up to 95 °F (-40 °C up to 35 °C)</p> |
| <p>Unocc TM Unoccupied Timer value Default 0.5 hours</p> | <p>Time delay between the moment where the Terminal Equipment Controller toggles from occupied to unoccupied after the last movement has been detected by the PIR. Range is: 0.5 to 24.0 hours in 0.5 hour increments</p> |
| <p>2/4event Number of events configuration Default value = 2 event</p> | <p>2 events, will set up scheduling for the following Event 1 is for Occupied setpoints Event 2 is for Unoccupied setpoints 4 events, will set up scheduling for the following Event 1 is for Occupied setpoints Event 2 is for Unoccupied setpoints Event 3 is for Occupied setpoints Event 4 is for Unoccupied setpoints</p> |

| <p>aux cont Auxiliary contact configuration Default value = N.O. normally open</p> | <p>This contact can be used to energize peripheral devices such as: lighting equipment, exhaust fans, economizers, etc. This contact will operate in parallel with the internal occupied/unoccupied schedule of the Terminal Equipment Controller or the remote NSB contact if DI1 or DI2 is used. When the system is in OFF mode, the contact will remain in its unoccupied status independently of the occupied / unoccupied schedule.</p> <table border="1" data-bbox="434 345 987 487"> <thead> <tr> <th>Configured</th> <th>Contact occupied status</th> <th>Contact unoccupied status</th> </tr> </thead> <tbody> <tr> <td>N.O.</td> <td>Closed</td> <td>Opened</td> </tr> <tr> <td>N.C.</td> <td>opened</td> <td>Closed</td> </tr> </tbody> </table> | Configured | Contact occupied status | Contact unoccupied status | N.O. | Closed | Opened | N.C. | opened | Closed |
|--|--|---------------------------|-------------------------|---------------------------|------|--------|--------|------|--------|--------|
| Configured | Contact occupied status | Contact unoccupied status | | | | | | | | |
| N.O. | Closed | Opened | | | | | | | | |
| N.C. | opened | Closed | | | | | | | | |
| <p>Prog rec Progressive recovery enabled Default value = Off Progressive recovery is automatically disabled if DI 1 and / or DI 2 are configured remote NSB</p> | <p>Off, = no progressive recovery The occupied schedule time is the time at which the system will restart. On, = progressive recovery active. The occupied schedule time is the time at which the desired occupied temperature will be attained. The Terminal Equipment Controller will automatically optimize the equipment start time. In any case, the latest a system will restart is 10 minutes prior to the occupied period time.</p> | | | | | | | | | |
| <p>Dis HL Discharge air temperature high limit Default: 120°F</p> | <p>Discharge air high temperature value at which the heating output will be locked out. 70°F to 150°F (21°C to 65°C) (increments: 0.5° or 5°)</p> | | | | | | | | | |
| <p>Dis LL Discharge air temperature low limit Default: 45°F</p> | <p>Discharge air low temperature value at which the cooling stages will be locked out. 35°F to 65°F (2.0°C to 19.0°C) (increments: 0.5° or 5°)</p> | | | | | | | | | |
| <p>MS dis Display mixed air temperature Economizer model only, only if sensor is installed</p> | <p>Used as diagnostic / service help to troubleshoot and diagnose economizer operation.</p> | | | | | | | | | |

DISCHARGE AIR CONTROL

The Viconics VT7600F controller has the ability to maintain a minimum heating supply temperature by using an analog 0-10VDC proportional output instead of using the staging outputs which will cause the unit to cycle. Using a full proportional output to maintain the minimum heating supply temperature can increase cost savings and less wear and tear on HVAC equipment.

The desired minimum setpoint temperature value can be set under the Min SH parameter and the following conditions must apply:

- The system mode is heating.
- The occupancy mode is in Occupied or Temporary Override.
- The OA temperature value is below SH lockout parameter value.

SPECIFICATIONS

Terminal Equipment Controller power

| | |
|--|---|
| requirements: | 19-30 VAC 50 or 60 Hz; 2 VA Class 2 RC to RH jumper 2.0 Amps 48VA max. |
| Operating conditions: | 0 °C to 50 °C (32 °F to 122 °F) 0% to 95% R.H. non-condensing |
| Storage conditions: | -30 °C to 50 °C (-22 °F to 122 °F) 0% to 95% R.H. non-condensing |
| Sensor: | Local 10 K NTC thermistor |
| Resolution: | ± 0.1 °C (± 0.2 °F) |
| Temperature control accuracy: | ± 0.5 °C (± 0.9 °F) @ 21 °C (70 °F) typical calibrated |
| Contact output rating | Relay outputs: 30 VAC, 1 Amp. Maximum, 3 Amp. In-rush. |
| Occ, Stand-By and Unocc cooling setpoint range: | 12.0 to 37.5 °C (54 to 100 °F) |
| Occ, Stand-By and Unocc heating setpoint range: | 4.5 °C to 32 °C (40 °F to 90 °F) |
| Room and outdoor air temperature display range: | -40 °C to 50 °C (-40 °F to 122 °F) |
| Digital inputs: | Dry contact across terminal D11 |
| Analog outputs rating (BPD & AO) | 0 to 10 VDC into 2KΩ resistance min |
| Analog outputs accuracy (BPD & AO) | ± 3% typical |
| Wire gauge: | 18 gauge maximum, 22 gauge |
| Approximate shipping weight: | 0.75 lb (0.34 kg) |
| Agency Approvals all models: | UL: UL 873 (US) and CSA C22.2 No. 24 (Canada), File E27734 with CCN XAPX (US) and XAPX7 (Canada) Industry Canada: ICES-003 (Canada) FCC: Compliant to CFR 47, Part 15, Subpart B, Class A (US) CE : EMC Directive 2004/108/EC (Europe Union) C-Tick: AS/NZS CISPR 22 Compliant (Australia / New Zealand) Supplier Code Number N10696 |
| Agency Approvals all models: | FCC: Compliant to: Part 15, Subpart B, Class (US) |
| Agency Approvals Wireless models: | |

THIS DEVICE COMPLIES WITH PART 15 OF THE FCC RULES. OPERATION IS SUBJECT TO THE FOLLOWING TWO CONDITIONS: (1) THIS DEVICE MAY NOT CAUSE HARMFUL INTERFERENCE, AND (2) THIS DEVICE MUST ACCEPT ANY INTERFERENCE RECEIVED, INCLUDING INTERFERENCE THAT MAY CAUSE UNDESIRED OPERATION



Please check with your local government for instruction on disposal of this product

DRAWING & DIMENSIONS

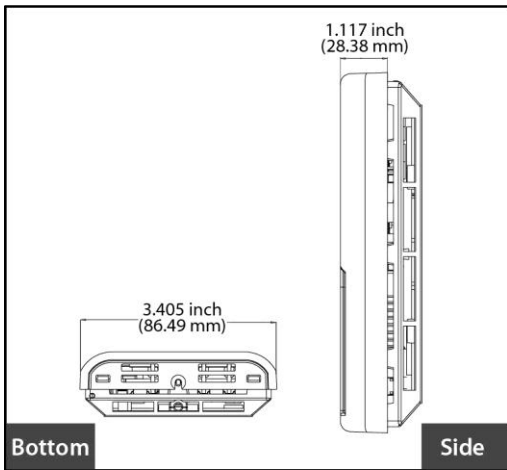
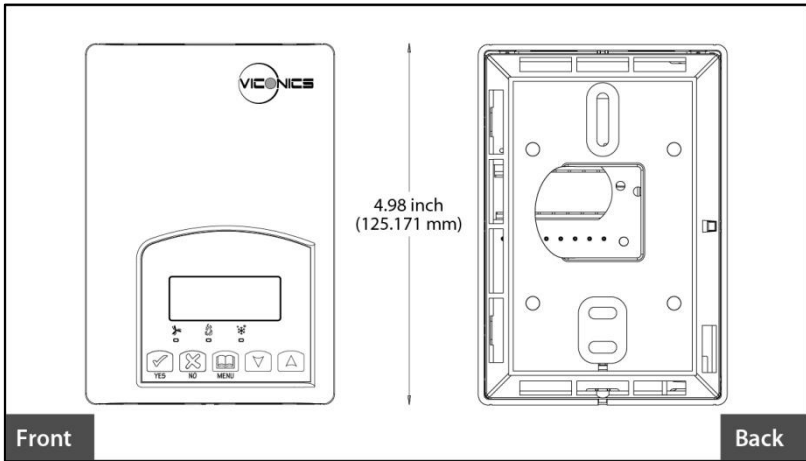

Viconics Technologies Inc.
9245 Langelier Blvd. | St-Leonard | Quebec | Canada | H1P 3K9
Tel.: (514) 321.5660 | Fax: (514) 321.4150 Toll free: 1 800.563.5660
sales@viconics.com | www.viconics.com