



## R850 SERIES R850V STEP CONTROLLER WITH INTEGRATED VERNIER STAGE

- Pulsed or analog 0 to 10 Vdc vernier stage
- 8 step models
- Up to 16 stage total with a slave unit
- Test button



### DESCRIPTION

The Viconics R850V series step controller is designed for cost-effective, precise modulation of multi-stage control applications. A common application is a multi-step electric duct heater.

An integrated vernier control output will give a precise and full modulation of the load from 0 to 100% of the total capacity.

### FEATURES AND BENEFITS

Microcomputer-based design	Accuracy and reliability
Adjustable inter-stage delay	Provides flexibility in replacement applications
Adjustable Vernier ratio	Simplifies design of proportional stage
Choice of pulsed or analog Vernier output	Permits use of SCR or lower cost SSR
Up to 16 stages	One product family can handle all applications
Choice of LIFO or FIFO sequencing	Increased flexibility of FIFO permits even use of contactors
Test button	Quick troubleshooting

### MODELS AVAILABLE

The R850V is available in 1 model

**R850V-8** 8 stage unit

If more than 8 stages are required, the R850V-8 can be used as a master unit with another R850V as a slave unit. Adding another unit can bring the total step number up to 16.

### INPUT SIGNAL

The R850V has four **INPUT** dip switches (**S1 to S4**) to select the control signal input: They are compatible with industry-standard signals.

### DIP SWITCH ADJUSTMENTS & WIRING CONTROL INPUT

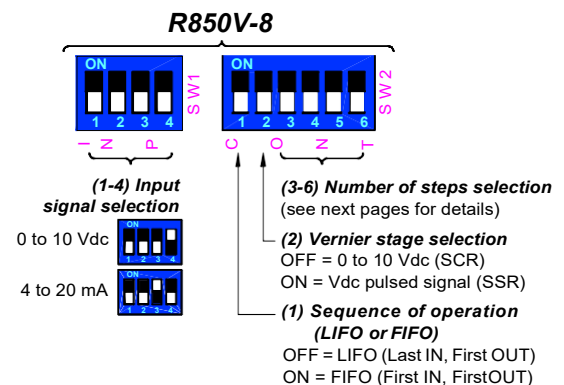

### OVERRIDE TEST BUTTON

The override test button can be used to by-pass the interstage delay and bring on all stages at one time. This simplifies the verification of the configured maximum number of stages.

A status LED per step will come on for each of the configured stages.

### SPECIFICATIONS

Agency cULus

Approval:

Operating 0°C to 80°C ( 32°F to 176°F )

Conditions: 0 % to 95 % R.H. non-condensing

Relay outputs: Isolated relay 30 Vac @ 1.0 amps. max. per output, up to a maximum of 4.0 amps. total per R850 controller. See application note 02.

Vernier stage: Vdc pulsed: 6 Vdc, 30 mA max.  
0 to 10 Vdc 5 mA max.

Input impedance: 0 to 10 Vdc into 10 K $\Omega$  minimum

Power supply: 24 Vac -15%, +10% 50/60 Hz; 4 VA

Use a Class 1 ( properly fused ) or Class 2, CSA or UL recognized transformer for power supply & relay outputs.

Specifications and equipment are subject to change without prior notice.

Input Signal Switch	Switch #1	Switch #2	Switch #3	Switch #4
0 to 10 Vdc control signal ( 2 to 10 Vdc control range )	Off	Off	Off	On
4 to 20 mA control signal	Off	Off	On	Off
0 to 135 $\wedge$ control signal	On	On	Off	Off

If a slave unit is used, wire the control signal input to the master unit only

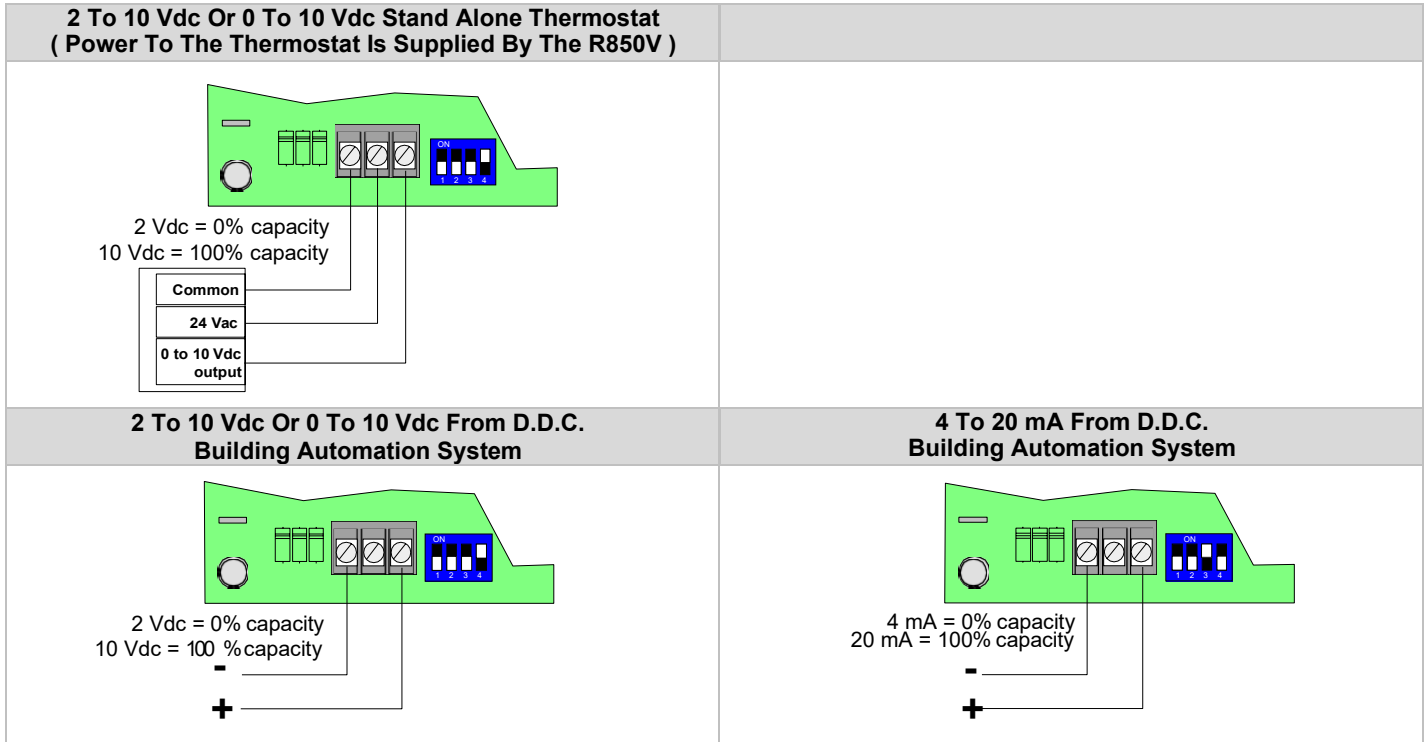

## 24 VAC POWER & RELAY OUTPUT WIRING

The wiring diagrams are for the R850V-8 models with 8 outputs.

### Terminals

Screw terminal & connector #1	Common
Screw terminal & connector #2	24 Vac
Screw terminal & connector #3	Control Signal input

- It is not necessary to ground any leg of the transformer to earth with the controller card.
- The controller uses internally a half-wave rectifier bridge. On 0 to 10 Vdc control signal, the reference of the control signal is the Common of the power supply of the SCR controller card.
- Use a Class 1 ( properly fused ) or Class 2, CSA or UL recognized transformer.

• 8 STAGE APPLICATION

R850V-8

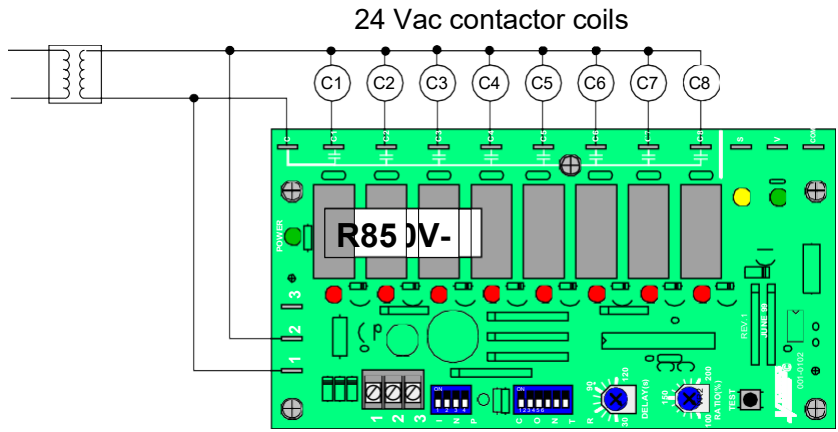

Number of stage
1
2
3
4
5
6
7
8

R850V-8 Control Switch				
Switch #3	Switch #4	Switch #5	Switch #6	
Off	Off	Off	Off	Off
On	Off	Off	Off	Off
Off	On	Off	Off	Off
On	On	Off	Off	Off
Off	Off	On	Off	Off
On	Off	On	Off	Off
Off	On	On	Off	Off
On	On	On	Off	Off

• 16 STAGE APPLICATION

R850V-8 MASTER UNIT, R850V-4 SLAVE UNIT

( See also slave application section at the end )

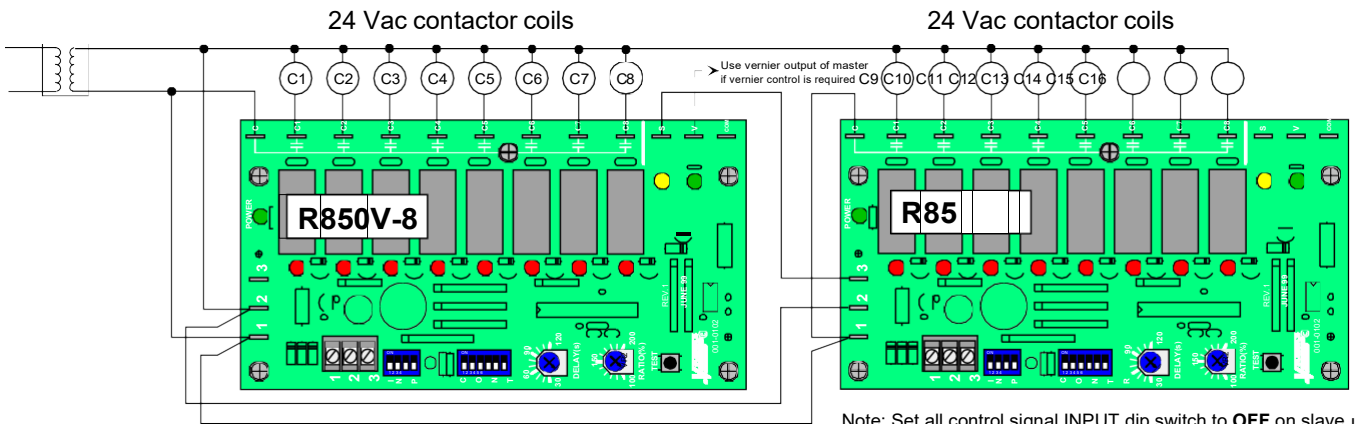

Note: Set all control signal INPUT dip switch to OFF on slave unit.

Number of stage
9
10
11
12
13
14
15
16

R850V-8 Master Unit Control Switch				
Switch #3	Switch #4	Switch #5	Switch #6	
Off	Off	Off	On	
On	Off	Off	On	
Off	On	Off	On	
On	On	Off	On	
Off	Off	On	On	
On	Off	On	On	
Off	On	On	On	
On	On	On	On	

R850V-8 Slave Unit Control Switch				
Switch #3	Switch #4	Switch #5	Switch #6	
Off	Off	Off	Off	
On	Off	Off	Off	
Off	On	Off	Off	
On	On	Off	Off	
Off	Off	On	Off	
On	Off	On	Off	
Off	On	On	Off	
On	On	On	Off	

The intensity of the yellow status LED on the master unit is proportional to the slave output.

## R850V DIMENSIONS & INSTALLATION

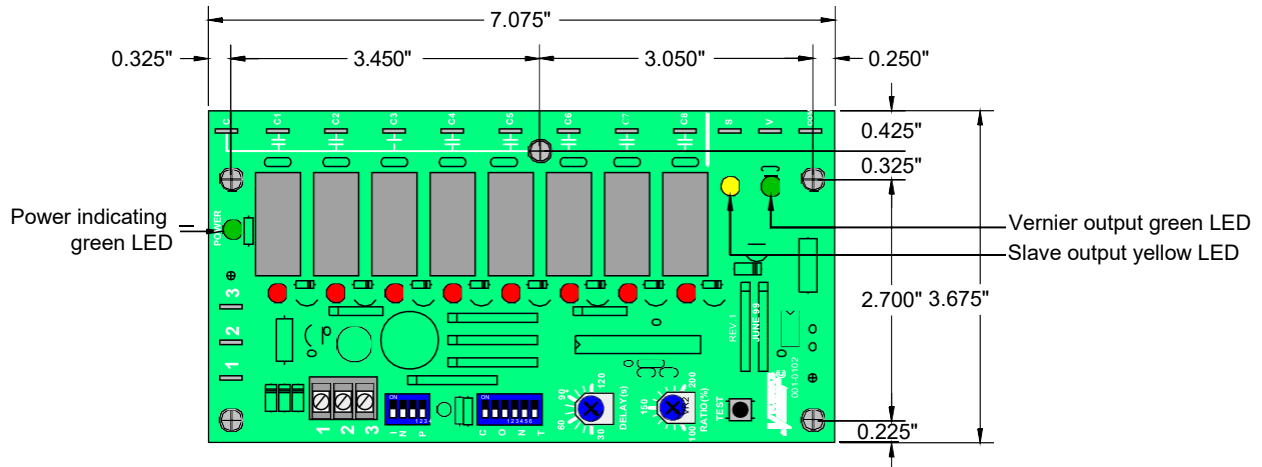

Install on the mounting plate on the electrical cabinet using five #6 pan head metal screws. Do not over-torque the screws to prevent damage to the board. Specifications and equipment are subject to change without prior notice.



All R850V series controls are for use only as operating controls. Whenever a control failure could lead to personal injury and/or loss of property, it becomes the responsibility of the user to add safety devices and/or alarm system to protect against such catastrophic failures.

## LIFO / FIFO ADJUSTMENT

The R850V series features 2 different staging sequences:

- **LIFO LAST IN FIRST OUT ( CONTROL SWITCH #1 OFF, FACTORY DEFAULT )**

This is the regular mode, Stage #1 will always be the first to energize and the last stage to de-energize

- **FIFO FIRST IN FIRST OUT ( CONTROL SWITCH #1 ON )**

In this mode, the stages are rotated to ensure a more uniform wear of the contactors and elements. For example, on an increase in demand, stage 1 will be energized following stage 2, etc. On a decrease in demand, stage 1 will be de-energized first followed by stage 2, etc.



**Please verify that if this mode is enabled, the manufactured product still complies with active codes and regulations.**

## VERNIER STAGE SELECTION AND WIRING

The Viconics R850V series step controller has an integrated vernier control output. This output will give a precise and full modulation of the load from 0 to 100% of the total capacity of the unit. If a master-slave application is used, always connect the vernier output of the master unit.

## ADJUSTMENTS

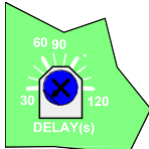
Functions of the units can be configured with six dip switch and 2 potentiometers.

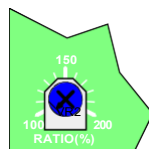
	<p><b>Interstage delay potentiometer setting</b> A potentiometer is used to adjust the interstage delay from 30 seconds up to 120 seconds.</p> <p>This delay is active in 3 ways.</p> <ul style="list-style-type: none"> <li>• Minimum time delay between each step activation when the control signal rises</li> <li>• Minimum ON time when the step is activated</li> <li>• Minimum time delay between each step de-activation when the control signal drops</li> </ul>	
	<p><b>Vernier stage ratio</b> A potentiometer is used to adjust the vernier stage ratio from 100% to 200% capacity of the other on/off stage capacity.</p>	

## RATIO SETTING ( See also slave application section at the end )

First, adjust the vernier stage ratio potentiometer. This will ensure a smooth capacity rise of the total load.

Example 1:

The total unit has 100 kW divided into 10 equal stages of 10 kW.

If only 10 kW is used as the modulating stage, then the heater would have 9 on/off mechanical stage plus one modulating stage. This modulating stage has the same value as all the other stages. **Adjust the vernier stage ratio potentiometer to 100%.**

Example 2:

The total unit still has 100 kW divided into 10 equal stages of 10 kW.

If 20 kW is used as the modulating stage, then the heater would have 8 on/off mechanical stage plus one modulating stage. The modulating stage has twice the value as all the other stages. **Adjust the vernier stage ratio potentiometer to 200%.**

## TYPE OF VERNIER STAGE SETTING

The vernier stage output can be configured to operate either as a:

- Vdc pulsed output to activate an R810 power module
- 0 to 10 Vdc analog output to activate an R820 SCR power controller.

## VERNIER STAGE WIRING

### Control Switch #2 On

### Vdc pulsed to activate R810 power modules

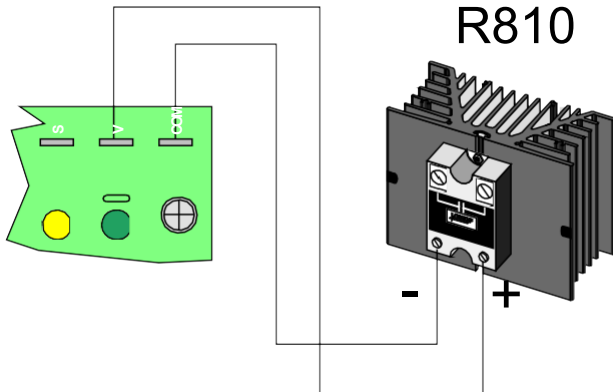
	<p><b>R810</b></p> <p>Do not wire more than six R810 power module on the vernier stage output</p> <p>Respect the polarity between the R850 step controller board an the R810 power modules</p> <p>Connect <b>V to +</b> Connect <b>COM to -</b></p> <p>The green status LED on the master unit will cycle at the same rate as the time proportioning vernier output</p> <p>For more information, please refer to the R810 service manual</p>
---	--

Set the **R820 SCR** power controller to accept a 0 to 10 Vdc control signal input  
Switch #1, #2 & #3 Off    Switch #4 On

The intensity of the green status LED on the master unit is proportional to vernier output

For more information, please refer to the R820 service manual

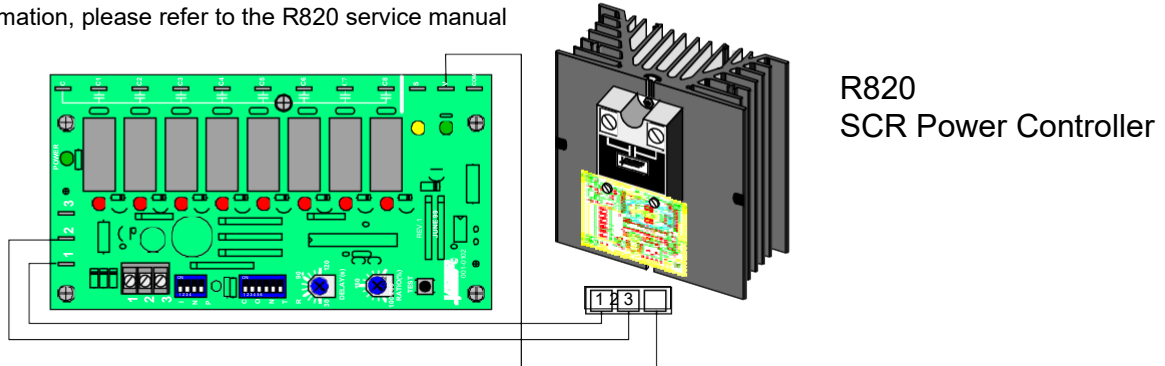

R820  
SCR Power Controller

## SLAVE APPLICATION SECTION

When using a unit for slave applications, it is important that the proper adjustments & settings be made to the unit for proper operation of the system.

The yellow LED near the vernier output connector is proportional to the vernier output of the master unit ( 0 to 5 Vdc ).

### On the slave unit:

- Set vernier ratio potentiometer to 100%
- Set interstage delay potentiometer to the same value as the master unit
- Set all control signal **INPUT** dip switch to **OFF**

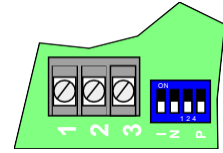

## TEST MODE BUTTON

The test mode button can be used to verify if the number of stages has been configured properly.

1. Press and hold the button for 3 to 4 seconds.
2. If a slave unit is used, press & hold the 2 units button simultaneously
3. All the selected stage will come on, one after the other until all selected number of stages are all on.
4. There is a delay of approximately 5 seconds between each step activation.
5. When all selected stages are on, they will stay on for approximately 30 seconds before shutting down.qww

Powering up the R850V controller while holding down the test button will by-pass the interstage delay for 10 minutes. During that period, the unit will respond to a changing signal input very rapidly. Also, hold down the slave test button on start-up if a slave unit is used. After 10 minutes, the unit will function normally with the interstage delays active

## CALIFORNIA PROPOSITION 65

### **⚠ WARNING**

#### CALIFORNIA PROPOSITION 65

This product can expose you to chemicals including Lead, which is known to the State of California to cause cancer and birth defects or other reproductive harm. For more information, go to [www.P65Warnings.ca.gov](http://www.P65Warnings.ca.gov).

**Failure to follow these instructions can result in birth defects or other reproductive harm.**



Viconics Technologies Inc.

7262 Marconi | Montreal | Quebec | Canada | H2R 2Z5

Tel.: 514.313.8885 | Toll free: 1 800.563.5660

[sales@viconics.com](mailto:sales@viconics.com) | [www.viconics.com](http://www.viconics.com)