

INTRODUCTION

Used in conjunction with any Badger Meter Impeller flow monitor or transmitter, Badger Meter non-magnetic flow sensors provide an accurate reading of the rate of liquid flow as well as total accumulated flow. A number of sensor models are offered, which cover applications for a wide range of pipe sizes and pressure/temperature specifications.

The flow sensors generate a frequency which is proportional to flow rate. An internal preamplifier allows the pulse signal to travel up to 2000 feet without further amplification. Power to operate the sensor is provided by the flow monitor. The impeller bearing assembly, shaft and O-rings are replaceable in the field.

Badger Meter flow sensors feature a closed, six-bladed impeller design, using a proprietary, non-magnetic sensing technology. The forward-swept impeller shape provides higher, more constant torque than four-bladed impeller designs, and is less prone to fouling by water-borne debris. The forward-curved shape, coupled with the absence of magnetic drag, provides improved operation and repeatability, even at lower flow rates. As the liquid flow turns the impeller, a low impedance signal is transmitted with a frequency proportional to the flow rate.

Sensors of similar type are interchangeable, so there is no need for recalibration after servicing or replacement.

ELECTRONIC TYPES

Badger Meter provides several basic sensor configurations using the same impeller element. This allows for a wide range of applications and pipe sizes. Sensors are normally supplied with 20 feet of 2-conductor 20 AWG shielded U.L. type PTLC 105°C cable. Optional sensors designated with the prefix "IR" feature two single conductor 18 AWG solid copper wire leads 48 inches in length with U.L. Style 116666 direct burial insulation. These IR models are used in below grade applications such as irrigation, municipal, and groundwater monitoring. All Series 200 sensor electrical components are self-contained. Pressure/temperature ratings for the various models are contained in the *Specifications* section of this manual. These models can be further described as follows:

"Standard" Sensor

Designed for indoor or protected area applications such as HVAC, pump control, and industrial process monitoring where the flow rates are between 0.5-30 feet/second and temperatures are below 221°F. Standard sensors are supplied with 20 feet of 2-conductor 20 AWG shielded U.L. type PTLC 105°C cable.

"IR" Sensor

Designed for below grade applications such as irrigation, municipal, and groundwater monitoring where the flow rates are between 0.5-30 feet/second and temperatures are below 180°F. IR sensors are supplied with two single conductors, 18 AWG solid copper wire leads 48 inches in length with U.L. Style 116666 direct burial insulation.



* These items must be special ordered

"High Temperature" Sensor

Designed for indoor or protected area applications such as hydronic heating loops, boiler feed, and condensate return line monitoring where the flow rates are between 0.5-30 feet/second and temperatures may be up to 285 deg. F. High temperature Series 228 and 250 sensors are supplied with 12 inches of 2-conductor 20 AWG shielded U.L. type PTLC 105°C cable inside the electronics housing.

"FM/CSA" Sensor

Designed for indoor or protected area applications where intrinsic safety is required and the flow rates are between 0.5-30 feet/second and temperatures are below 221 deg. F. FM/CSA sensors are supplied with 20 feet of 2-conductor 20 AWG shielded U.L. type PTLC 105°C cable. These sensors must be used with an approved safety barrier.

"Magnetic" Sensor

Designed for use with the Badger® Series 1400 battery powered flow monitor in above or below or grade applications such as irrigation, municipal, and groundwater monitoring where the flow rates are between 1-30 feet/second and temperatures are below 221 deg. F.

Models 220BR, 220PVS, 225BR, 226BR, 220SS and 226SS

Model 220BR

This insert style sensor has a 5 1/4 inch long sleeve length, and uses brass and bronze hardware. It is used in all pipe sizes from 2.5 inch to 40.0 inch in diameter. A bronze 2 inch NPT externally threaded hex adapter is provided. The adapter may be mounted to the pipe using a welded-on threaded fitting such as a Thredolet® or pipe saddle.

Model 220PVS

This insert style sensor has an 8 inch long sleeve length, and uses PVC and stainless steel hardware. It is used in all pipe sizes from 2.5 inch to 40.0 inch in diameter. A PVC 2 inch NPT externally threaded hex adapter is provided. The adapter may be mounted to the pipe using a pipe saddle.

Model 220SS

This is the same as Model 220BR, except that the sensor, sleeve and hex adapter are made of Series 300 stainless steel.

Models 225BR

This insert style sensor has a 16 3/8 inch long sleeve length, and uses brass and bronze hardware for hot tap installations. It has a bronze isolation gate valve for applications where the pipe is drained for initial installation but cannot be drained for service.

Models 226BR

This is the same as Model 225BR, except that it has a ball type isolation valve. The ball valve allows for higher pressure use. We recommend this sensor when installation is to be made under pressure, in a true "hot tap" installation. The ball valve cannot be fouled by the tailings from the cutting operation.

200 Series Insert Style Matrix (sizes 2 1/2" and up)

Example: 2		x	x	x	x	x	-	x	x	x	x
STYLE											
Short Insert	20										
Hot Tap Insert-Gate Valve	25										
Hot Tap Insert-Ball Valve	26										
MATERIAL											
Brass										BR	
Stainless Steel										SS	
PVC Sleeve w/Stainless Steel Trim										PVS	
Size											
Insert Style										00	
Electronics Housing											
PPS										0	
ELECTRONICS											
Magnetic										2	
FM/CSA Approved										4	
Standard										5	
IR-Irrigation										6	
High Temperature										8	
O-RING											
Viton®										0	
EPDM										1	
Kalrez®										2	
Food Grade Silicon										3	
Neoprene										4	
Chemraz®										5	
Teflon Encapsulated Viton										6	
Teflon Encapsulated Silicone										7	
Buna N										8	
SHAFT											
Zirconia Ceramic										0	
Hastalloy® C										1	
Tungsten Carbide										2	
Titanium										3	
Monel®										5	
316 Stainless Steel										6	
Tantalum										7	
IMPELLER											
Nylon											1
Tefzel®											2
BEARING											
Pennlon®											1
Tefzel											2
Teflon®											3

Models 226SS, IR226SS

This is the same as Model 226BR respectively, except that the hot tap hardware, ball valve, and sensor sleeve are made of Series 300 stainless steel.

Model HTT

This is the insertion tool for use with any of the hot tap sensor units. It is used to insert and remove the sensor while under pressure. Generally, only one HTT tool is needed on each job site.

MECHANICAL INSTALLATION

General

The accuracy of flow measurement for all flow measuring devices is highly dependent on proper location of the sensor in the piping system. Irregular flow velocity profiles caused by valves, fittings, pipe bends, etc. can lead to inaccurate overall flow rate indications even though local flow velocity measurement may be accurate. A sensor located in the pipe where it can be affected by air bubbles, floating debris, or sediment may not achieve full accuracy and could be damaged. Badger Meter flow sensors are designed to operate reliably under adverse conditions, but the following recommendations should be followed to ensure maximum system accuracy:

- 1) Choose a location along the pipe where 10 pipe diameters upstream and 5 pipe diameters downstream of the sensor provide no flow disturbance. Pipe bends, valves, other fittings, pipe enlargements and reductions should not be present in this length of pipe.

- 2) The preferred location around the circumference of a horizontal pipe is on top. If trapped air or debris will interfere, then the sensor should be located further around the pipe from the top but not more than 45 degrees from top dead center. The sensor should never be located at the bottom of the pipe, as sediment may collect there. Locations off top dead center cause the impeller friction to increase, which may affect performance at low flow rates. Any circumferential location is correct for installation in vertical pipes.

- 3) An insertion depth of 1 1/2 inches for pipe sizes 2.5 inches and larger is required for accurate flow rate calibration. Detailed installation instructions for various sensor mounting configurations on the following pages include methods for ensuring correct insertion depth.

- 4) Alignment of the sensor to ensure that impeller rotation is parallel to flow is important. Alignment instructions are also included on the following pages.

INSTALLATION FOR 220BR, 220SS

Installation Procedure

The insertion depth and alignment of the sensor assembly are critical to the accuracy of the flow measurement. The flat end of the sensor tube assembly **MUST BE INSTALLED** 1-1/2 inches from the inside wall of the pipe. In order to allow for variations in wall thickness, lining, or coatings the depth adjustment is controlled by the position of the Hex Nuts on the three (3) threaded studs of the hex mounting adapter. The hex mounting adapter is provided with a 2 inch male NPT connection.

There are two methods of mounting these Badger Meter sensors in a 2.5 inch or larger pipe. One is with a 2 inch NPT threaded pipe saddle. The other is with a welded-on fitting such as a Thredolet®, also tapped for a 2 inch NPT connection. In either case, cut a 2 inch hole through a depressurized pipe and then secure the saddle or weld-on fitting to the pipe. (For drilling into a pressurized pipe, see instructions for Series 225 and 226 sensors.) Install the 2 inch NPT adapter provided, using a thread sealant to prevent leakage. Tighten as necessary. Badger Meter insert style sensors are calibrated with the sensor inserted 1 1/2 inches into the pipe flow.

To determine the proper insertion depth, proceed as follows:

- 1) **Apply anti-seize thread lubricant , supplied with the sensor, to the threaded studs of the mounting adaptor.**
- 2) Insert the depth gauge into the mounting adapter and set it against the inside wall of the pipe as shown. Set the top of the upper adjusting nut to 3 3/4 inches as measured. Lock it in place with the bottom nut on the same stud. Repeat for the other adj. nuts.

Note: For Model 220PVS: Set nuts 6.5 inches above inside wall of pipe.

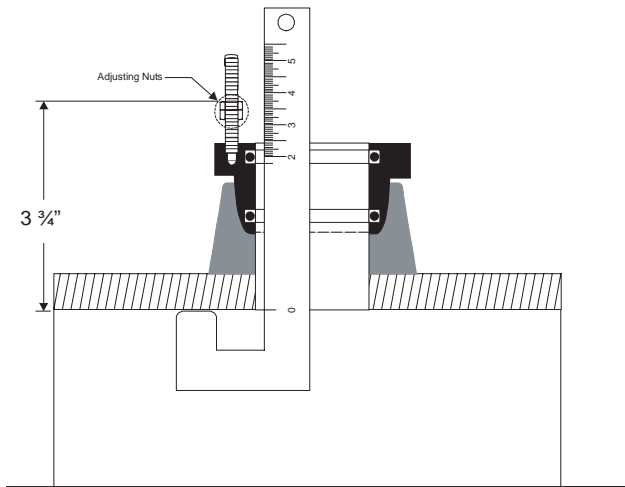

Figure 1
Installation for 220BR and 220SS

- 3) Clean O-rings and flow sensor sleeve, and lightly lubricate O-rings with silicone grease from the packet provided or some other acceptable lubricant. Take care not to get grease on the impeller or bearing.
- 4) Insert the flow sensor into the 2 inch NPT adapter so that the mounting holes in the positioning collar fit over the studs on the adapter. Lower the sensor onto the previously adjusted nuts. Install the lock nuts on top of the positioning collar and tighten. Now tighten the lower jam nuts firmly against the upper adjusting nuts to secure them for future removal of the sensor for inspection or service.

Alignment of Flow Sensor

- 1) Loosen positioning collar set screws with a 3/32 inch Allen wrench. Place the alignment rod through the sight holes in the flow sensor. Refer to Figure 2. Using the alignment rod as a guide, align the flow sensor so that the flow label arrow matches pipe flow direction and so that the alignment rod is exactly parallel to the pipe. This procedure aligns the impeller directly into the fluid flow.

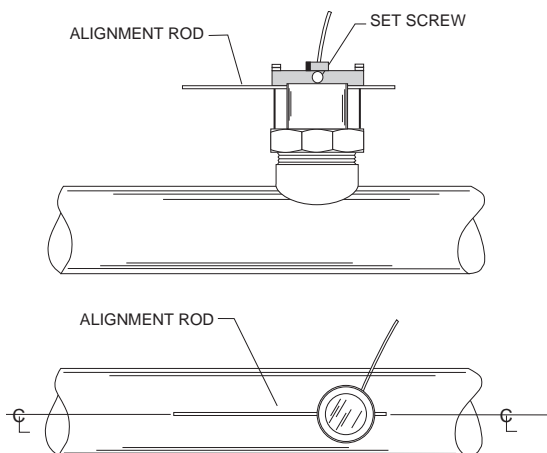

Figure 2
Alignment of Flow Sensor in 220BR and 220SS

- 2) As a backup to the flow arrow label, there is a small hole next to the larger sighting hole of the upstream side. With a 3/32 inch Allen wrench, tighten positioning collar set screws.
- 3) Double check that the sighting holes in the sleeve are parallel down the pipe and that the flow arrow label matches pipe liquid flow direction.
- 4) Cable routing: The positioning collar is threaded for connection of a standard 1/2 inch electrical conduit (flex cable) or a wire strain relief. Route cable as required. Be sure to leave enough flex in cable or conduit to allow future removal of sensor for service or cleaning if necessary.

Hot Tap Installation for 225BR, 226BR, and 226SS

Badger Meter Series 200 hot tap style liquid flow sensors are designed for use in cases where pipelines will be in continuous service and depressurizing or draining the system for installation or service is not practical.

The Badger® Series 200 hot tap sensors are designed to be installed either in a depressurized pipe by hand or “Hot Tapped” into a pressurized pipeline. Both installation procedures are listed in this installation and operation manual. If there is the slightest possibility that the pipe could be full or pressurized, **FOLLOW THE INSTALLATION FOR PRESSURIZED PIPE.**

Refer to Figure 3 for location or identification of the various parts described in the following procedures.

The insertion depth and alignment of the sensor assembly are critical to the accuracy of the flow measurement. The flat end of the sensor tube assembly **MUST BE INSTALLED** 1 1/2 inches from the inside wall of the pipe. In order to allow for variations in wall thickness, lining or coatings the depth adjustment is controlled by the position of the hex nuts on the three threaded studs of the hex mounting adapter. The hex mounting adapter is provided with a 2 inch male NPT connection. Both gate and ball valve units are provided with 2 inch nipples for mounting onto saddles, weld-o-lets, etc.

Depth setting is accomplished by positioning the hex nuts 14 7/8 inches minus the thickness of the pipe, from the outside diameter of the pipe. For example, measure the wall thickness of the pipe from the coupon removed when the 1 7/8 inch hole was cut into the pipe. If the pipe was 1/8 inch thick, subtract 1/8 inch from 14 7/8 inch, or position the nuts 14 3/4 inch from the outside diameter of the pipe. This will allow the 16 3/8 inch sensor to protrude 1 1/2 inch into the pipe.

Apply anti-seize thread lubricant, supplied with the sensor, to the threaded studs of the mounting adaptor.

The alignment of the impeller with the flow in the pipe is accomplished by aligning the two “sight holes” at the top of the sensor tube assembly with the center line of the pipe.

Make sure the alignment is made to the pipe and not to a wall or surface near the sensor. To adjust, loosen the two set screws in the positioning collar with a 3/32 inch Allen wrench provided in the Series 200 hot tap installation kit. Slip one end of the 1/4 inch x 18 inch steel rod (also supplied in the installation kit) through the holes in the sensor tube. Rotate the sensor tube until the rod is centered on the pipe. Ensure the flow label “Arrow” on the sensor matches

the liquid flow direction. Tighten the positioning collar Allen screws to lock the sensor tube assembly in position. Note: As a backup to the flow direction arrow label on the tube assembly, there is a smaller hole located beside one of the sighting holes in the tube, to also indicate the upstream side of the tube assembly.

If the pipe is depressurized and drained

- 1) Drill or cut a 1 7/8 inch hole in the pipe with a drill or hole saw. Note the pipe wall thickness for use in calculating sensor assembly depth. A location on the top of the pipe is best for overall performance and service life; however, any radial location on the top half of the pipe is acceptable. Allow a minimum of ten pipe diameters upstream and five downstream from the sensor of straight unobstructed pipe to allow full development of the flow profile.
- 2) Install either a service saddle or welded pipe fitting (2 inch female NPT) on the outside diameter of the pipe over the 1 7/8 inch hole.
- 3) Install the Badger Meter isolation valve and nipple onto the fitting using pipe thread sealant or Teflon® tape on all threads.
- 4) Install the Badger Meter hex mounting adapter onto the valve assembly. Use pipe thread sealant on the adapter. Tighten the hex adapter so that no stud is aligned with the center-line of the pipe. This could interfere with final sensor alignment. Measure depth and set the height of the nuts of the hex mounting adapter.
- 5) Open the bleed petcock valve on the hex adapter to relieve the pressure as the sensor tube is installed. Carefully hand insert the Badger Meter hot tap flow sensor tube into the hex mounting adapter. The sleeve should be inserted past the top two O-rings in the adapter (approx. 1 - 1 1/4 inches). **Take care not to push the tube in too far as the impeller could be damaged if it strikes the closed valve.**
- 6) Even if the sensor is installed with system drained, Badger Meter recommends that a HTT, hot tap insertion/removal tool be purchased for future service. This tool allows the sensor tube assembly to be removed from the pipe line without draining the entire loop where the sensor is mounted.
- 7) In a fully depressurized and drained pipe, the sensor tube assembly may be installed by hand. **Carefully and very slowly** open the isolation valve to relieve any pressure that may have built up. Fully open the isolation valve. Push the sensor tube into the pipe with a slight twisting motion. Guide the sensor collar holes over the three hex adapter studs until the collar rests on the nuts. Hex nuts should have been previously set to the correct height. Install the three lock nuts onto these studs at the top of the positioning collar and securely tighten.

- 8) Loosen the two set screws in the positioning collar with a 3/32 inch Allen wrench. Align the sensor sight holes along the pipe axis using the alignment rod provided in the installation kit supplied with the sensor. Ensure that the flow label arrow on the sensor matches the liquid flow direction inside the pipe. Tighten the positioning collar set screws. Note: As a backup to the flow label arrow, there is a small hole located beside one of the sighting holes to also indicate the upstream side of the sensor.

INSTALLATION INTO A PRESSURIZED PIPELINE USING MODEL HTT.

For information on installing hot tap sensor with older 225H consult technical bulletin DID-001

For pipe sizes 2½” and above; all Badger Meter sensors are inserted 1 1/2” from the inside wall of the pipe. The insertion depth is controlled by the position of the hex nuts on the three threaded rods. The formula below defines the distance between the top of the sensor hex mounting adaptor and the bottom of the positioning collar (the top of the hex nut). Reference Figure 3.

$$D = 16 \frac{3}{8}'' - (H + \text{Pipe Wall Thickness} + 1.5 '')$$

Example: If sensor is installed in a 8 inch Sch 80 pipe with a pipe wall thickness of 1/2 inch and the “H” dimension is 10 inches then the calculation would be as below:

$$D = 16 \frac{3}{8}'' - (10 \text{ inches} + 0.5 \text{ inches} + 1.5 \text{ inches})$$

$$D = 4 \frac{3}{8}''$$

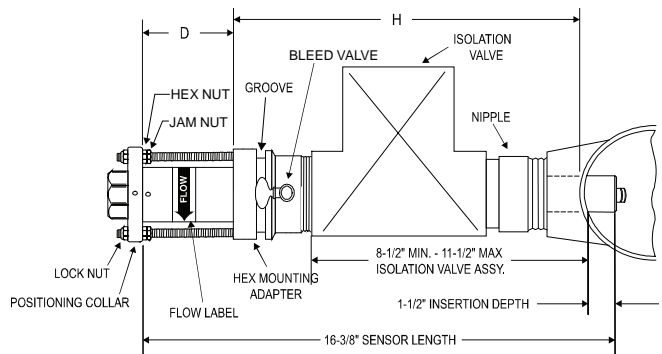

Figure 3

1. Set one set of hex/jam nuts so that the distance between the top surface of the hex nut and the top surface of the hex mounting adaptor is equal to the "D" dimension calculated above. Then adjust the other two sets of hex/jam nuts 1½ inches below the first jam nut to allow clearance for the tool top yoke.
2. Remove the tool split ring and clevis pin and slide tool bottom yoke into the groove on the sensor hex mounting adaptor and secure by replacing the clevis pin and split ring.
3. Mark sleeve 2¾ inches from impeller end of metal sleeve. This mark is a stopping point to insure that impeller/bearing is not damaged. Open the bleed petcock valve on the hex adapter to relieve the pressure resulting from the sensor tube insertion. Carefully hand insert the Badger Meter hot tap flow sensor sleeve assembly into the hex mounting adapter until the mark lines up with the top of the hex mounting adapter. At this point the sleeve will have been inserted past the top two "O"-rings in the adapter (approx. 1 1-1/4 inches). Take care not to push the sensor past the mark on the sleeve as the impeller could be damaged if it strikes the closed valve.
4. Fully extend tool by turning drive nut counterclockwise with a 15/16 inch socket or box wrench (not provided) until drive nut contacts tool and slide the positioning collar into the tool top yoke.
5. Rotate tool so the threaded rod with the adjusted hex/jam nuts is centered in the top yoke of hot tap tool.
6. Rotate sensor sleeve so positioning collar holes align with the threaded rods and flow direction label is in general direction making sure the positioning collar is located in the recessed area of the top yoke. Slide the top yoke of the tool over the positioning collar and secure by tightening the two thumbscrews on the top of the yoke.
7. Close the bleed petcock and slowly open the isolation valve. Slowly turn the 15/16 inch drive nut clockwise to insert the sensor tube assembly through the valve and into the pipeline. Carefully guide the three threaded studs of the hex mounting adapter through the holes of the sensor positioning collar. Carefully lower the sensor until the positioning collar contacts the hex nut preset for the correct depth adjustment. Install the three lock nuts onto the threaded rods, tightening only the lock nut on the threaded rod with the preset hex/jam nut; then, bring the two remaining lock nuts down until they just contact the positioning collar. Do not tighten at this time
8. Remove the Model HTT Insertion/Removal Tool, by loosening the two thumbscrews, removing the clevis pin and then sliding the insertion tool off the sensor. Then bring the two remaining sets of hex/jam nuts up to the underside of the positioning collar, and tighten.
9. Align the sensor by first loosening the two set screws in the side of positioning collar with a 3/32 inch Allen wrench. Then align the sensor sight holes along the pipe axis using the alignment rod provided in the sensor installation kit. Ensure that the flow label arrow on the sensor matches the liquid flow direction inside the pipe. Tighten the positioning collar set screws. Note: As a backup to the flow label arrow, there is a small hole located beside the sight hole on the upstream side of the sensor.

Electrical Installation "Standard" sensors

- 1) The metal collar on the top of the 220 sensors or an optional conduit cap on the Series 250 sensors will accept 1/2 inch threaded conduit fittings.
- 2) Route the cable from the sensor to a Badger Meter flow monitor/transmitter. The cable may be extended up to 2000 feet, using 2-conductor shielded 20 AWG or larger stranded copper wire. Be sure to leave enough flexibility in the cable or conduit to allow for future service of sensor, if necessary.
- 3) When connecting to a Badger Meter flow monitor/transmitter, locate the section of terminal strip on the monitor labeled "SENSOR INPUT" or "SENSOR". Connect the red wire to "IN", "SIGNAL(+)" or "SIGNAL" terminal and the black wire to "GND", "SIGNAL(-)", or "COM" terminal and the shield drain wire (if applicable) to "SLD".
- 4) When interfacing with other equipment consult manufacture for input designations. The signal wave forms and power requirements are as shown in the specifications section. Refer to Technical Bulletin DTB-058 at www.badgermeter.com

Electrical Installation "IR" sensors

The sensor leads are supplied with watertight caps over the ends. See Application Note DAB-031 and Technical Bulletin DID-003 at www.badgermeter.com

- 1) **DO NOT** remove the plastic caps from the sensor leads until ready to splice.
- 2) Use a **twisted pair** cable suitable for direct burial to connect the sensor to the transmitter, monitor, or controller. Multi-pair telecommunication cable or direct burial cables may be used.
- 3) Make a water tight splice. Two part epoxy type waterproof kits are recommended. Be sure the epoxy seals the ends of the cable jacket.
- 4) Make sure the epoxy is hardened before inverting the splice or dropping it in standing water.
- 5) **DO NOT** make an underground splice unless absolutely necessary.
- 6) Route the cable from the sensor to a Badger Meter flow monitor/transmitter. The cable may be extended up to 2000 feet, using 2-conductor shielded 20 AWG or larger stranded copper wire with appropriate ratings. Be sure to leave enough flexibility in the cable or conduit to allow for future service of sensor, if necessary.

- 7) When connecting to a Badger Meter flow monitor/transmitter, locate the section of terminal strip on the monitor labeled “**SENSOR INPUT**” or “**SENSOR**”. Connect the red wire to “**IN**”, “**SIGNAL(+)**” or “**SIGNAL**” terminal and the black wire to “**GND**”, “**SIGNAL(-)**”, or “**COM**” terminal and the shield drain wire (if applicable) to “**SLD**”.
- 8) When interfacing with other equipment, the signal wave forms and power requirements are as shown in the specifications section. Refer to technical bulletin DTB-058 at www.badgermeter.com

Electrical Installation "High Temperature" sensors

- 1) Route a cable from the sensor to a Badger Meter flow monitor/transmitter. The cable may be run up to 2000 feet, using 2-conductor shielded 20 AWG or larger stranded copper wire. Be sure to leave enough flexibility in the cable or conduit to allow for future service of sensor, if necessary.
- 2) Connect to cable inside sensor electronic housing on Series 220 sensors or attach to the sensor cable on the Series 225/226 and connect with standard wire nuts.
- 3) When connecting to a Badger Meter flow monitor or transmitter, locate the section of terminal strip on the monitor labeled “**SENSOR INPUT**” or “**SENSOR**”. Connect the red wire to “**IN**”, “**SIGNAL(+)**” or “**SIGNAL**” terminal and the black wire to “**GND**”, “**SIGNAL(-)**”, or “**COM**” terminal and the shield drain wire (if applicable) to “**SLD**”.
- 4) When interfacing with other equipment, the signal wave forms and power requirements are as shown in the specifications section.

Electrical Installation "Magnetic" sensors

The magnetic sensor has a custom wire connector that connects to the series 1400 monitor only. The cable may be extended up to 100 feet from the sensor. If extension cables are needed they may be ordered from Badger Meter.

Cable Length	Part #
5'	7101
10'	7108
20'	7102
50'	7109

Electrical Installation (FM Sensors)

The Badger® Series 200 sensor is approved, as an entity, as intrinsically safe when installed in conformance with Badger Meter installation drawings 06-480-001 or 06-480-002 (samples shown on Page 10) as specified on the blue label identifying an intrinsically safe sensor.

Entity approval implies that only the sensor is approved as intrinsically safe. Unless power supplies, equipment, and instruments connected to the sensor are each rated either explosion-proof or intrinsically safe, these devices cannot be installed in a hazardous area. The referenced installation drawing shows such apparatus located in a non-hazardous location. Proper interfacing between the hazardous and non-hazardous areas must be provided. It is of absolute importance that this interface be constructed and that all wiring be performed by qualified contractors. To ensure the intrinsic safety of the installation, the connection of the intrinsically safe sensor to instruments and or power supplies must take place using an approved intrinsically safe barrier located in a non-hazardous area. These barriers, listed below, are readily available from various suppliers.

Manufacturer:	Barrier:
Crouse-Hinds Spec 504	Cat No.SB19140M0715
Measurement Technology Ltd.	MTL 715+ 15 V
R Stahl Intrinspak	9001/1-158-150-10

THIS DOCUMENT CONTAINS INFORMATION PROPRIETARY TO DATA INDUSTRIAL. NEITHER RECEIPT NOR POSSESSION HEREOF CONFERES ANY RIGHT TO REPRODUCE, USE, OR DISCLOSE, IN WHOLE OR IN PART, ANY SUCH INFORMATION WITHOUT WRITTEN AUTHORIZATION OF DATA INDUSTRIAL.

REVISIONS			
REV	DESCRIPTION	DATE	BY
A	RELEASED ECD 3250		
B	ECD 3263	7-6-94	
C	ECD 3292	12/27/94	
D	ECD 3649	11/10/98	R.G.

HAZARDOUS LOCATION

NONHAZARDOUS LOCATION

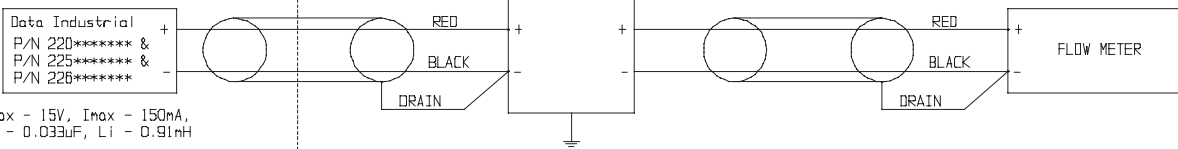

$V_{max} = 15V$, $I_{max} = 150mA$,
 $C_i = 0.033\mu F$, $L_i = 0.91mH$

USABLE IN HAZARDOUS LOCATIONS
 CLASS I, DIVISION 1,
 CLASS II, DIVISION 1,
 CLASS III, DIVISION 1,
 GROUPS A, B, C, D, E, F, G

FMRC APPROVED ENTITY
 INTRINSIC SAFETY BARRIER

NOTES

1. FMRC APPROVED BARRIER PARAMETERS MUST MEET THE FOLLOWING CONNECTION REQUIREMENTS:
 - V_{oc} OR V_t MUST BE LESS THAN V_{max}
 - I_{sc} OR I_t MUST BE LESS THAN I_{max}
 - C1 PLUS INTERCONNECTION WIRING MUST BE LESS THAN THE C_o OF THE FMRC APPROVED BARRIER
 - L1 PLUS INTERCONNECTING WIRING MUST BE LESS THAN THE L_o OF THE FMRC APPROVED BARRIER
2. INSTALLATION SHALL BE IN ACCORD WITH THE MANUFACTURER'S INSTRUCTIONS AND THE NATIONAL ELECTRICAL CODE (ANSI/NFPA 70).
3. FOR GUIDANCE ON INSTALLATION, SEE ANSI/ISA RP12.6 "INSTALLATION OF INTRINSICALLY SAFE INSTRUMENT SYSTEMS IN CLASS I HAZARDOUS LOCATIONS"
4. NO CHANGES TO THIS DRAWING WITHOUT PRIOR WRITTEN AUTHORIZATION FROM FMRC.

DO NOT SCALE DRAWING

DRAWN BILL HEELAN	DATE 04/20/94		11 INDUSTRIAL DRIVE MATTAPANSETT, MA 02739 (508)-750-6390	
CHECKED	DATE		PROJECT FM APPROVED SENSORS	
APPROVAL	DATE	PART INSTALLATION DRAWING FOR FMRC APP' D 220CP, 220PV, 220BR*, 220SS*, 225*, & 226*-SENSORS		
FMRC APPROVAL	DATE	SIZE B	FSCH NO.	DWG NO. 06-480-001
		SCALE NONE	06480001D.PRT	SHEET 1 OF 2

THIS DOCUMENT CONTAINS INFORMATION PROPRIETARY TO DATA INDUSTRIAL. NEITHER RECEIPT NOR POSSESSION HEREOF CONFERES ANY RIGHT TO REPRODUCE, USE, OR DISCLOSE, IN WHOLE OR IN PART, ANY SUCH INFORMATION WITHOUT WRITTEN AUTHORIZATION OF DATA INDUSTRIAL.

REVISIONS			
REV	DESCRIPTION	DATE	BY
A	RELEASED ECD 3250		
B	ECD 3263	7-6-94	
C	ECD 3292	12/27/94	
D	ECD 3649	11/10/98	R.G.

HAZARDOUS LOCATION

NONHAZARDOUS LOCATION

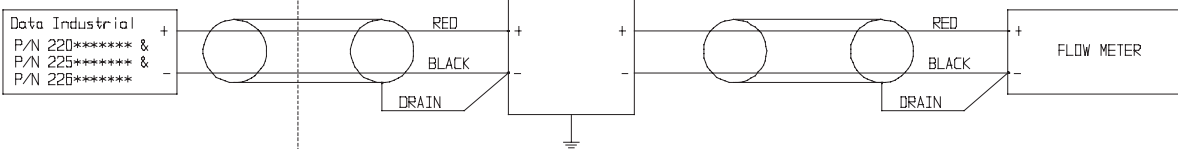

USABLE IN HAZARDOUS LOCATIONS
 CLASS I, DIVISION 1,
 CLASS II, DIVISION 1,
 CLASS III, DIVISION 1,
 GROUPS A, B, C, D, E, F, G

CSA CERTIFIED
 INTRINSIC SAFETY BARRIER

CROUSE-HINDS, SPEC 504, CAT. NO. SB19140M0715
 MEASUREMENT TECHNOLOGY LTD. MTL 715+ 15 V,
 R. STAHL INTRINSPAK 9001/01-158-150-10

NOTES:

1. INSTALLATION SHALL BE IN ACCORD WITH THE INTRINSIC SAFETY BARRIER MANUFACTURERS INSTRUCTIONS AND CANADIAN ELECTRICAL CODE
2. NO CHANGES TO THIS DRAWING WITHOUT PRIOR WRITTEN AUTHORIZATION FROM CSA

DO NOT SCALE DRAWING

DRAWN BILL HEELAN	DATE 04/20/94		11 INDUSTRIAL DRIVE MATTAPANSETT, MA 02739 (508)-750-6390	
CHECKED	DATE		PROJECT CSA CERTIFIED SENSORS	
APPROVAL	DATE	PART INSTALLATION DRAWING FOR CSA CERTIFIED 220CP, 220PV, 220BR*, 220SS*, 225*, & 226*-SENSORS		
FMRC APPROVAL	DATE	SIZE B	FSCH NO.	DWG NO. 06-480-001
		SCALE NONE	06480001D.PRT	SHEET 2 of 2

Calibration

Badger Meter sensors use unique K and Offset numbers for calibration. These numbers are derived from calibration runs using NIST traceable instruments. Using both a K and an Offset number provides higher accuracy than using a K (pulse/gal) factor alone. K and Offset numbers for each tee configuration are listed in the following tables.

Calibration Tables

The table on pages 12 and 13 provides calibration and operation data for most scheduled pipe sizes from 3 inches through 18 inches. For tee-mounted sensors, see either Metal Tee (Manual Number 872021), or (Plastic Tee Manual Number 872022).

Description of Column Information for Pipe Sizes 3 inches through 36 inches

Column 1	Nominal Pipe Size
Column 2	Pipe O.D. as defined by ASA B36.10 and other standards
Column 3	Pipe I.D. as defined by ASA B36.10 and other standards
Columns 4 and 5	The K value and Offset that should be used in our frequency equation: This equation describes the frequency

$$\text{Freq} = \frac{\text{Gpm}}{K} - \text{Offset}$$

of the output signal of all Badger Meter flow sensors. By substituting the appropriate K and Offset values from the table, the sensor's output frequency can be calculated for each pipe size. This information is required when calibrating an output board or when using the raw sensor data as direct output to interface with a device that is not a Badger Meter product.

Column 6

This column indicates the suggested flow range of sensors in each pipe size. Badger Meter sensors will operate both above and below the indicated flow rates. However, good design practice dictates the use of this range for best performance.

Sensors should be sized for flow rather than pipe size. To prevent disturbances to the flow profile always connect the sensor tee to pipe nipples measuring at least ten pipe diameters in length on the up stream (supply) side and at least five pipe diameters in length on the downstream (delivery) side before making the transition in pipe size.

Column 1	Column 2	Column 3	Column 4	Column 5	Column 6
Pipe Size	Pipe O.D.	Pipe I.D.	K	Offset	Suggested Operating Range (GPM)
3 inch Sch 10S	3.500"	3.260"	5.009	.090	12-400
Std. Wt., Sch 40	3.5"	3.068"	4.362	.063	12-400
Extra Strong, Sch 80	3.5"	2.900"	3.858	.043	12-400
PVC Class 125	3.5"	3.284"	5.094	.093	12-400
PVC Class 160	3.5"	3.230"	4.902	.085	12-400
PVC Class 200	3.5"	3.166"	4.682	.076	12-400
4 inch Sch 10S	4.5"	4.260"	9.597	.241	20-600
Std. Wt., Sch 40	4.5"	4.026"	8.34	.229	20-600
Extra Strong, Sch 80	4.5"	3.826"	7.354	.188	20-600
PVC Class 125	4.5"	4.224"	9.396	.240	20-600
PVC Class 160	4.5"	4.154"	9.013	.240	20-600
PVC Class 200	4.5"	4.072"	8.578	.239	20-600
5 inch Sch 10S	5.563"	5.295"	16.305	.250	30-900
Std. Wt., Sch 40	5.50"	5.047"	14.674	.248	30-900
Extra Strong, Sch 80	5.50"	4.813"	13.165	.246	30-900
6 inch Sch 10S	6.625"	6.357"	24.089	.260	50-1,500
Std. Wt., Sch 40	6.5"	6.065"	21.574	.257	50-1,500
Extra Strong, Sch 80	6.5"	5.761"	19.457	.254	50-1,500
PVC Class 125	6.625"	6.217"	22.853	.258	50-1,500
PVC Class 160	6.625"	6.115"	21.968	.257	50-1,500
PVC Class 200	6.625"	5.993"	21.068	.256	50-1,500
8 inch Sch 10S	8.625"	8.329"	43.914	0.286	80-2,500
Sch 20	8.625"	8.125"	41.653	0.283	80-2,500
Sch 30	8.625"	8.071"	41.063	0.283	80-2,500
Std. Wt., Sch 40	8.625"	7.981"	40.086	0.281	80-2,500
Sch 60	8.625"	7.813"	38.288	0.279	80-2,500
Extra Strong, Sch 80	8.625"	7.625"	36.315	0.276	80-2,500
PVC Class 125	8.625"	8.095"	41.324	0.283	80-2,500
PVC Class 160	8.625"	7.961"	39.869	0.281	80-2,500
PVC Class 200	8.625"	7.805"	38.203	0.279	80-2,500
10 inch Sch 10S	10.75"	10.420"	70.195	0.321	125-4,000
Sch 20	10.75"	10.250"	67.668	0.318	125-4,000
Sch 30	10.75"	10.136"	66.069	0.316	125-4,000
Sch 40, Std.Wt.	10.75"	10.020"	64.532	0.314	125-4,000
Extra Strong, Sch 60	10.75"	9.750"	61.016	0.309	125-4,000
Sch 80	10.75"	9.564"	58.644	0.306	125-4,000
PVC Class 125	10.75"	10.088"	65.431	0.315	125-4,000
PVC Class 160	10.75"	9.924"	63.272	0.312	125-4,000
PVC Class 200	10.75"	9.728"	60.733	0.309	125-4,000
12 inch Sch 10S	12.75"	12.390"	104.636	0.367	175-5,000
Sch 20	12.75"	12.250"	102.553	0.364	175-5,000
Sch 30	12.75"	12.090"	99.347	0.36	175-5,000
Std. Wt., Sch 40S	12.75"	12.000"	97.576	0.358	175-5,000
Sch 40	12.75"	11.938"	96.369	0.356	175-5,000
Sch 60	12.75"	11.625"	90.441	0.348	175-5,000
Extra Strong	12.75"	11.750"	92.775	0.351	175-5,000
Sch 80	12.74"	11.376"	85.922	0.342	175-5,000
PVC Class 125	12.75"	11.966"	96.912	0.357	175-5,000
PVC Class 160	12.75"	11.770"	93.152	0.352	175-5,000
PVC Class 200	12.75"	11.538"	88.842	0.346	175-5,000

CALIBRATION TABLE FOR PIPE SIZES 3 INCHES THROUGH 36 INCHES

Continued on Next Page

Column 1	Column 2	Column 3	Column 4	Column 5	Column 6
Pipe Size	Pipe O.D.	Pipe I.D.	K Value	Offset	Suggested Operating Range (GPM)
14 inch Sch 10S	14.00"	13.500"	122.307	0.391	200-6,000
Sch 20	14.00"	13.375"	120.216	0.388	200-6,000
Std. Wt., Sch 30	14.00"	13.250"	118.151	0.385	200-6,000
Sch 40	14.00"	13.124"	116.096	0.382	200-6,000
Sch 60	14.00"	12.814"	111.148	0.376	200-6,000
Extra Strong	14.00"	13.00"	114.098	0.33	200-6,000
Sch 80	14.00"	12.50"	106.299	0.369	200-6,000
16 inch Sch 10S	16.00"	15.500"	159.243	0.44	300-9,000
Sch 20	16.00"	15.375"	156.742	0.436	300-9,000
Std. Wt., Sch 30	16.00"	15.250"	154.267	0.433	300-9,000
Sch 60	16.00"	14.688"	143.456	0.419	300-9,000
Extra Strong, Sch 40	16.00"	15.000"	149.394	0.427	300-9,000
Sch 80	16.00"	14.314"	136.548	0.41	300-9,000
18 inch Sch 10S	18.00"	17.500"	202.739	0.498	350-10,000
Sch 20	18.00"	17.375"	199.828	0.494	350-10,000
Sch 30	18.00"	17.124"	194.061	0.486	350-10,000
Std. Wt.	18.00"	17.250"	196.943	0.49	350-10,000
Sch 40	18.00"	16.876"	188.464	0.479	350-10,000
Sch 60	18.00"	16.500"	180.171	0.469	350-10,000
Extra Strong	18.00"	17.000"	191.25	0.482	350-10,000
Sch 80	18.00"	16.126"	172.152	0.457	350-10,000
20 inch Std. Wt., Sch 20	20.00"	19.25"	246.179	0.555	400-12,000
Sch 40	20.00"	18.812"	234.836	0.540	400-12,000
Extra Strong, Sch 30	20.00"	19.000"	239.666	0.547	400-12,000
Sch 80	20.00"	17.938"	213.14	0.511	400-12,000
22 inch Std. Wt., Sch 20	22.00"	21.25"	301.975	0.621	500-15,000
Extra Strong, Sch 30	22.00"	21.00"	294.642	0.616	500-15,000
Sch 80	22.00"	19.75"	259.513	0.573	500-15,000
24 inch Std. Wt., Sch 20	24.00"	23.25"	364.331	0.666	600-18,000
Extra Strong	24.00"	23.00"	356.178	0.660	600-18,000
Sch 40	24.00"	22.624"	344.109	0.652	600-18,000
Sch 80	24.00"	21.562"	311.271	0.628	600-18,000
26 inch Sch 10	26.00"	25.376"	437.809	0.719	700-21,000
Std. Wt.	26.00"	25.25"	433.247	0.716	700-21,000
Sch 20, Extra Strong	26.00"	25.00"	424.274	0.709	700-21,000
28 inch Sch 10	28.00"	27.376"	513.698	0.774	900-23,000
Std. Wt.	28.00"	27.25"	508.723	0.770	900-23,000
Extra Strong, Sch 20	28.00"	27.00"	498.930	0.763	900-23,000
30 inch Sch 10	30.00"	29.376"	596.147	0.833	1,000-30,000
Std. Wt.	30.00"	29.25"	590.759	0.829	1,000-30,000
Sch 20, Extra Strong	30.00"	29.00"	580.146	0.822	1,000-30,000
32 inch Sch 10	32.00"	31.376"	685.156	0.897	1,200-35,000
Std. Wt.	32.00"	31.25"	679.355	0.893	1,200-35,000
Sch 20, Extra Strong	32.00"	31.00"	667.922	0.885	1,200-35,000
Sch 40	32.00"	30.624"	650.919	0.873	1,200-35,000
34 inch Sch 10	34.00"	33.312"	777.566	0.964	1,300-40,000
Std. Wt.	34.00"	33.25"	774.511	0.962	1,300-40,000
Extra Strong, Sch 20	34.00"	33.00"	762.258	0.953	1,300-40,000
Sch 40	34.00"	32.624"	744.022	0.940	1,300-40,000
36 inch Sch 10	36.00"	35.376"	882.855	1.040	1,500-45,000
Std. Wt.	36.00"	35.25"	876.227	1.035	1,500-45,000
Sch 20, Extra Strong	36.00"	35.00"	863.154	1.025	1,500-45,000
Sch 40	36.00"	34.50"	837.315	1.007	1,500-45,000

CALIBRATION TABLE FOR PIPE SIZES 3 INCHES THROUGH 36 INCHES

Impeller Assembly and Shaft Replacement

If you are replacing an existing Badger Meter sensor and have already calibrated your flow monitor/transmitter, no calibration changes are necessary. For installation of a new flow monitor or for relocation of a sensor in a new pipe size, please refer to the calibration instructions in flow monitor manual.

- 1) Depressurize pipe from which sensor is to be removed. If the sensor is one of the Series 225/IR225 or 226/IR226, consult the installation section on hot tap sensors.

NEVER disturb the securing lock nuts with pipe under pressure without hot tap insertion tool Model HTT installed.

- 2) Remove the three lock nuts that secure the positioning collar to the threaded rods of metal sensor.

NOTE: Before removing lock nuts, record the dimension from top of 2 inch NPT adapter to the bottom of the positioning collar. This dimension will be required later to reinstall.

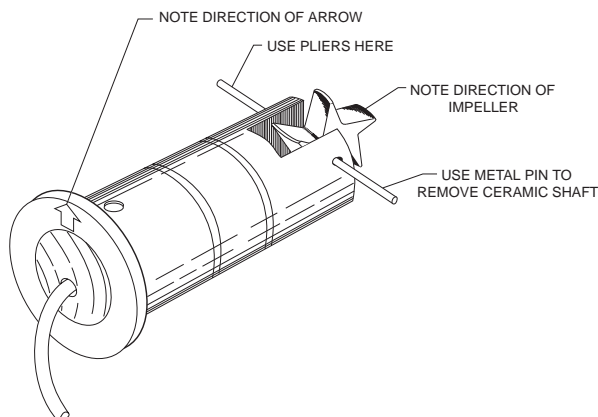

Figure 4
Impeller Assembly and Shaft Replacement

- 3) Remove the sensor from the hex adapter or the tee.
- 4) Note the impeller blade orientation relative to flow arrows and the alignment hole in metal sensors beside one of the sighting holes. In order to maintain proper calibration, the impeller will have to be reinstalled in the same manner with the impeller blades pointing toward the small alignment hole, and into the flow direction as indicated by the flow arrows.
- 5) To remove the old impeller blade assembly, push the old shaft out of the sleeve with the new shaft (or small diameter rod) just far enough to grab the end with a pair of pliers and pull the shaft completely out. The impeller assembly will now be free and will drop out.
- 6) Inspect the shaft and bearings for wear, and replace as necessary.
- 7) Refer to figure 4. To reinstall, position the impeller in the cavity oriented as in step 4 so that the impeller blades point into the flow direction and toward the small alignment hole located beside one of the sighting holes on metal sensors.

- 8) Carefully push the shaft through the sleeve and impeller taking care not to damage the bearings. Make sure that the shaft is inserted far enough so that it clears the sleeve on each side of the impeller housing.

NOTE: If shaft is not carefully installed, the bearing can be deformed preventing free rotation.

- 9) Inspect the O-rings for damage and replace as necessary. Clean the O-rings and the sleeve and relubricate with silicone grease from the packet provided or some other acceptable lubricant.
- 10) Install the sensor into the 2 inch NPT adapter or tee so that alignment hole is facing upstream and flow arrows point in the direction of the actual flow. Since the positioning collar was not loosened during this operation, the studs should all line up perfectly when the sighting holes are parallel to pipe. If this has been accidentally loosened, please refer to the installation instructions for the alignment of the flow sensor unit.
- 11) Install and tighten the nuts.
- 12) For metal sensors, double check that the distance from the top of the 2 inch NPT adapter to the bottom of the positioning collar equals the dimension as measured in step 2, and holes in sleeve sight exactly down the pipe, the arrows point in direction of flow and alignment holes located beside one sighting hole is pointing towards the source. If not, refer to *installation* section in this manual.
- 13) This completes the replacement procedure. The system may now be repressurized and tested.

TROUBLESHOOTING

- 1) If the voltage at the sensor input is less than 7 VDC in a no flow situation, disconnect the sensor from the barrier strip and measure the voltage at the sensor input terminals of the barrier strip again. It should be between 8 VDC and 20 VDC. If the voltage at the sensor input is still below 7 VDC or 3 VDC, the problem may be with the monitor (hardware or programming).
- 2) If you suspect that the sensor is bad, you can test the monitor circuitry by connecting a piece of wire to one of the sensor input terminals and tap the other side of the wire to the other sensor input terminal. Shorting across the sensor input terminals ON and OFF repeatedly allows the display to respond by trying to calculate a flow rate for the frequency of your shorting action. If the display does not show a change from 0.00, it indicates a problem with the monitor.
- 3) If the monitor tests ok and there are any splices in the cable, break the sensor cable at the splice closest to the sensor and retry the shorting test in step 2.
- 4) If the cable tests ok, drain the pipe line, verify the pressure is off, remove top lock nuts holding the sensor electronics. Spin the impeller by hand. If flows are noted on the display, and impeller spins freely then the flow rates may have been below our design minimums or the line was full of air. Try again. If the sensor fails to respond then replace sensor.

SPECIFICATIONS

Wetted Materials for all sensors

- (see ordering matrix)

Sensor Sleeve and Hex Adapter for 220BR, 225BR, and 226BR

- Sleeve: admiralty brass, UNS C44300; hex adapter: valve bronze, UNS C83600

Sensor Sleeve and Hex Adapter for 220SS and 226SS

- Series 300 stainless steel

Temperature Ratings

- Standard version:
 - 221 deg. F (105 deg. C) continuous service
- High temperature version:
 - 285 deg. F (140.6 deg. C) continuous service
 - 305 deg. F (150 deg. C) peak temperature (limited duration)

Pressure Ratings

	At 100 deg. F	At 300 deg. F
220SS	400 psi	325 psi
220B	400 psi	325 psi
225B	300 psi	210 psi
226B	400 psi	250 psi
226SS	400 psi	300 psi

Recommended Design Flow Range

- 0.5 to 30 ft/sec
- Initial detection below 0.3 ft/sec

Accuracy

- $\pm 1.0\%$ of full scale over recommended design flow range

Repeatability

- $\pm 0.3\%$ of full scale over recommended design flow range

Linearity

- $\pm 0.2\%$ of full scale over recommended design flow range

Transducer Excitation

- Quiescent current 600uA@8VDC to 35VDC max.
- Quiescent voltage (V_{high})
Supply Voltage $-(600uA * \text{Supply impedance})$
- ON State (V_{Low}) Max. 1.2VDC@40mA current limit (15ohm+0.7VDC)

Output Frequency

- 3.2 Hz to 200 Hz

Output Pulse Width

- 5 msec $\pm 25\%$

Electrical Cable for Standard Sensor Electronics

- 20 feet of 2-conductor 20 AWG shielded U.L. type PTLC wire provided for connection to display or analog transmitter unit. Rated to 105 deg. C. May be extended to a maximum of 2000 feet with similar cable and insulation appropriate for application.

Electrical Cable for IR Sensor Electronics

- 48 inches of U.L. Style 116666 copper solid AWG 18 wire with direct burial insulation. Rated to 105 deg. C.

(This page intentionally left blank.)

(This page intentionally left blank.)

(This page intentionally left blank.)

Badger® and Data Industrial® are registered trademarks of Badger Meter, Inc.
Monel® is a registered trademark of Inco Alloys International, Inc.
Pennlon® is a registered trademark of Dixon Corporation.
Chemraz® is a registered trademark of Greene Tweed of Delaware, Inc.
Viton®, Kalrez®, Tefzel®, and Teflon® are registered trademarks of E.I. DuPont de Nemours and Company.
Hastalloy® is a registered trademark of the Haynes Stellite Company.
Threadolet® is a registered trademark of Bonney Forge & Tool Works Corporation.



Please see our website at www.badgermeter.com
for specific contacts.

Copyright © Badger Meter, Inc. 2009. All rights reserved.

Due to continuous research, product improvements and enhancements, Badger Meter reserves the right to change product or system specifications without notice, except to the extent an outstanding contractual obligation exists.



BadgerMeter, Inc.

6116 E. 15th Street, Tulsa, Oklahoma 74112

(918) 836-8411 / Fax: (918) 832-9962

www.badgermeter.com